

# ORTHO FAB

*Prima<sup>4</sup>*  
*Prima<sup>R</sup>*

---

## USER'S MANUAL



# ORTHO FAB

---



*Give this manual to the wheelchair occupant or the assistant if the occupant is unable to read it.*



*Please read the entire manual before using the wheelchair. Please refer to this manual as needed and pay close attention to the warnings until you are familiar with them. For electrically powered wheelchairs, pay close attention to the operating rules for the control system and battery charger.*



*If you have questions, please consult a technician at an authorized service centre or contact our customer service department at: 1-800-463-5293*

**Centre:** \_\_\_\_\_

**Address:** \_\_\_\_\_  
\_\_\_\_\_

**Phone:** \_\_\_\_\_



*Adjustments to your wheelchair should only be performed by health care professionals. Improper adjustments can cause injury and/or damage to the occupant, the assistant, the wheelchair, or the environment.*



*NEVER install accessories that are not authorized and approved by **ORTHO FAB**. Always consult a health care professional for any modifications to your wheelchair.*



*Please read the entire manual describing the control system of your Oasis PC or PP electrically powered wheelchair before first use, along with the battery charger manual. They are provided for your safety.*

# ORTHOFAB

---

As Quebec's only manufacturer of manual and electrically powered and tilt wheelchairs, **ORTHOFAB** is proud to offer high-quality wheelchairs, adapted to your needs and to your seating comfort, and we thank you for selecting one of our products. **ORTHOFAB** products comply with Quebec standard BNQ 6645-001 (2019), which specifies technical and documentary requirements for manufacturers of mobility devices. Our team is always ready to answer your comments and questions, guided by our commitment to your satisfaction and to providing the best possible service.

## WARRANTY

**ORTHOFAB** has a comprehensive warranty on mechanical and electronic parts and components.



***This warranty does not apply in case of breakage due to negligence, abuse and/or unauthorized installation of components. **ORTHOFAB** is not liable for any damage to persons or property resulting from improper or negligent use of its products, lack of care, or modifications made without its written consent.***



***The Prima 4 and Prima R (“Robust”) have different requirements and may have differences in operating procedures. Where required, this will be noted in the manual.***

<b>1. SAFETY RULES</b> .....	<b>6</b>
1.1. <i>General Information</i> .....	6
1.1.1. BEFORE YOU HIT THE ROAD.....	6
1.1.2. GETTING AROUND IN A WHEELCHAIR.....	7
1.1.3. CROSSING A SLOPE.....	8
1.1.4. TRANSFERRING.....	9
1.1.5. MISCELLANEOUS HANDLING.....	10
1.1.6. CLEANING AND DISINFECTING.....	11
1.2. <i>RECOMMENDED USE</i> .....	11
<b>2. TECHNICAL INFORMATION</b> .....	<b>12</b>
<b>3. ADJUSTMENTS</b> .....	<b>13</b>
3.1. <i>LEG SUPPORT ASSEMBLY</i> .....	13
3.1.1. LENGTH ADJUSTMENT.....	13
3.1.2. CHANGING THE ANGLE OF THE ADJUSTABLE ANGLE FOOT SUPPORT, SINGLE AND FULL WIDTH.....	14
3.1.3. CHANGING THE POSITION (DEPTH) OF THE ADJUSTABLE ANGLE PLATE.....	14
3.1.4. RETRACTING AND REMOVING THE LEG SUPPORT ASSEMBLY.....	15
3.1.5. TWO-PIECE FULL-WIDTH PLATE.....	16
3.1.6. DEPTH ADJUSTMENT OF HEEL SUPPORT STRAP.....	17
3.1.7. ADJUSTING THE FLAT PADDED LOWER LEG SUPPORT.....	18
3.2. <i>ARM SUPPORT</i> .....	19
3.2.1. ADJUSTING THE REMOVABLE T-SHAPED ARM SUPPORT.....	19
3.2.2. ADJUSTING THE REMOVABLE AND FOLDABLE U-SHAPED ARM SUPPORT.....	20
3.2.3. ADJUSTING THE REMOVABLE T-SHAPED ARM SUPPORT.....	21
3.3. <i>ANGLE-ADJUSTABLE BACK SUPPORT</i> .....	22
3.3.1. BACK SUPPORT ANGLE ADJUSTMENT.....	22
3.3.2. CHANGING BACK SUPPORT HEIGHT.....	23
3.4. <i>INSTALLING THE BACK SUPPORT TENSION BAR</i> .....	24
3.5. <i>SEAT</i> .....	25
3.5.1. REMOVING THE SEAT SLING.....	25
3.5.2. ADJUSTING THE SEAT SLING TENSION.....	26
3.6. <i>FLOOR-TO-SEAT HEIGHT AND CENTRE OF GRAVITY</i> .....	27
3.6.1. FRONT FLOOR-TO-SEAT HEIGHT ADJUSTMENT.....	27
3.6.2. REAR FLOOR-TO-SEAT HEIGHT ADJUSTMENT.....	28
3.6.3. ADJUSTING THE CENTRE OF GRAVITY.....	29
3.7. <i>REAR WHEELS</i> .....	30
3.7.1. THREADED AXLES.....	30
3.7.2. WHEEL WIDTH ADJUSTMENT.....	31
3.7.3. AIR TIRE PRESSURE.....	31
3.8. <i>FORK BRACKET</i> .....	32
3.8.1. PERPENDICULAR FORK ALIGNMENT.....	32
3.8.2. FORK BRACKET ORIENTATION.....	33
3.9. <i>LOCKING BRAKES</i> .....	34
3.9.1. BRAKE POSITION ADJUSTMENT.....	34
3.9.2. CHANGING OR INSTALLING A BRAKE LEVER EXTENSION.....	36
3.9.3. CHANGING THE BRAKE LEVER ANGLE (push brake only).....	36
3.10. <i>ANTI-TIPS</i> .....	38

3.10.1.	HEIGHT ADJUSTMENT OF ANTI-TILT DEVICES .....	38
3.11.	WHEELCHAIR HANDLING.....	38
3.11.1.	TO OPEN THE WHEELCHAIR .....	38
3.11.2.	TO FOLD THE WHEELCHAIR.....	40
3.12.	HEIGHT AND DEPTH ADJUSTABLE HEAD SUPPORT.....	40
3.13.	ADJUSTABLE TENSION BACK SUPPORT .....	42
3.14.	LOCKING BRAKES.....	44
3.14.1.	ENGAGING – RELEASING PUSH-TYPE BRAKES.....	44
3.14.2.	ENGAGING – RELEASING THE ANTI-REVERSE.....	45
3.15.	ANTI-TIP DEVICE .....	46
3.15.1.	TO REMOVE OR RETRACT.....	46
3.15.2.	RETRACTING .....	46
3.16.	PELVIC POSITIONING BELT .....	47
3.17.	HIP BELT .....	47
3.18.	SPECIALIZED TRANSIT.....	48
3.18.1.	INSTRUCTIONS FOR SPECIALIZED TRANSIT .....	53
4.	MAINTENANCE .....	55
5.	TROUBLESHOOTING GUIDE .....	57
6.	WARRANTY .....	58
	AUTHORIZED CENTRES .....	61

## 1. SAFETY RULES

### 1.1. General Information

(Applies to all **ORTHO FAB** wheelchairs)

	<p><i>The driving settings should only be adjusted and/or modified by a health care professional or an authorized service technician. Wheelchair use should be based on the occupant's cognitive and physical abilities. Only a qualified healthcare professional should provide an opinion in this regard.</i></p>
-----------------------------------------------------------------------------------	---------------------------------------------------------------------------------------------------------------------------------------------------------------------------------------------------------------------------------------------------------------------------------------------------------------------

#### 1.1.1. BEFORE YOU HIT THE ROAD

Check:

- Parking brakes engaged;
- Anti-tip device installed;
- Sufficient tire pressure;
- Stable seating position;
- Back support raised;
- Removable and/or retractable leg support and arm support locked;
- Lowered leg support;
- Pelvic positioning belt;
- Tilt mechanism in driving position;
- **Check that nothing interferes with the wheels (scarf, umbrella, coat hanging from the back support, loose clothing, etc.) and that no heavy objects are hanging from the back support;**
- If you own an Oasis PC, check that the battery is sufficiently charged and that the cables of the control box and parking light switch are correctly positioned to prevent wheel lock or interference with the environment;
- If you own an Oasis, check that the rubber protector under the joystick tip is in good condition (if not, have it repaired immediately).



*Never allow a child to play with or on the wheelchair, whether or not the occupant is sitting in it.*

## 1.1.2. GETTING AROUND IN A WHEELCHAIR

- Always use the pelvic positioning belt and adjust it properly;
- When faced with an obstacle, stop, and move forward gradually;
- Avoid slippery and uneven surfaces;
- Avoid sudden and abrupt turns;
- If unsure of surface conditions, bypass the area or avoid venturing out;
- If weather conditions are extreme or change abruptly, find shelter as soon as possible;
- Always make sure you are visible;
- Do not pull a trailer or carry passengers;
- Avoid hanging objects on the back support.

## 1.1.3. CROSSING A SLOPE

- The manual wheelchair can negotiate slopes at low speed, with a maximum incline of 10°, external or internal, and a length of at least 3 metres, alone or with an assistant. The assistant must always be at the back of the wheelchair, whether ascending or descending, and should hold the back support posts.
- Climb and descend slopes in a straight line, directly along the slope's axis, thus reducing the risk of a sideways rollover.
- **Do not approach slopes. If it is unavoidable, make sure you never climb or descend diagonally and always face forward. For manual and tilt wheelchairs, it is strongly recommended to approach slopes with an assistant, regardless of angle.**



*Comply with the above conditions to ensure the wheelchair's stability and ability to control the desired trajectory.*

*Ascending or descending an incline, either independently or with an assistant, is possible if the consulting or prescribing health care professional is satisfied that the occupant has the physical and cognitive skills to do so.*



## 1.1.4. TRANSFERRING

- Fold down foot support plates;
- We recommend that you remove the leg supports before transferring;
- Always apply the brakes before transferring or before sitting in the wheelchair;
- Never lean forward or backward to reach an object;
- Position yourself sideways to the object to be reached, as close as possible;
- Use the arm support transfer supports to help you stand up, after checking that they are securely in place;
- Do not sit on the back support if it is reclined;
- Never stand on the foot supports;
- Never sit on the arm supports;
- Always **switch off** the control box before transferring or transporting. Retract the control box if necessary.

## 1.1.5. MISCELLANEOUS HANDLING

- Never submerge your wheelchair or leave it in the rain for a prolonged period;
- Do not store your wheelchair in a damp or very cold place (this could cause serious damage);
- If the occupant remains seated in a wheelchair while travelling in a road vehicle designed for transporting disabled persons, make sure that the occupant, driver and the vehicle owner respect all legislative, regulatory, policy, guideline and standard requirements, instructions and recommendations of all competent authorities;
- When approaching an inclined surface in freewheel mode, the assistant should always be toward the bottom of the incline relative to the wheelchair;
- Do not attempt to lift or move the wheelchair by moving parts such as arm supports, leg support assemblies, seat, joystick, or cover. Use only non-removable, solid frame components.

## 1.1.6. CLEANING AND DISINFECTING

- To disinfect the wheelchair, first remove all accessories that require special treatment and those that cannot be treated:
- Special treatment: Any upholstery from which foam cannot be removed (back support, lower leg support, etc.). Disinfection by hand. First clean with a cloth and a cleaning agent, apply a disinfectant, wait the required time and then wipe dry.
- Not treatable: Electronic components (batteries, controllers, accumulator).
- Use a soft cloth to clean the control box and joystick as soon as they become soiled.
- Washing fabric: remove foam and machine wash the cover in warm water, delicate cycle, with mild soap. Hang to dry. Do not use alcohol-based detergents or thinners.
- For other components, we recommend using pre-moistened alcohol and/or quaternary ammonium wipes.



## 1.2. RECOMMENDED USE

Prima 4 and Prima R feature multiple adjustments that ensure proper positioning and seating comfort, using materials that include ergonomic elements for maximum propulsion. While the Prima 4 is suitable for occupants weighing up to 300 pounds, the Prima R offers the same advantages for anyone weighing up to 350 pounds. All three models are tested in accordance with BNQ 6645-001, which specifies requirements for wheelchairs and user documentation for all users.

## 2. TECHNICAL INFORMATION

<p><b>Dimensions</b></p> <p><b>Prima 4: BNQ 6645-001 FMA-GM2-C-P2</b>  <b>Weight:</b> 35 lbs</p> <p><b>Prima R: BNQ 6645-001 FMA-GM3-C-P2</b>  <b>Weight:</b> 37 lbs</p> <p><b>Maximum user weight:</b>  Prima 4: 300 lbs  Prima R: 350 lbs</p>	<p><b>Leg support assembly</b></p> <p>Swiveling in/out and removable  60° or 70° post with adjustable length from 12 to 19 in.  90° post with adjustable length from 14 to 19 in.  Height-adjustable leg supports, from 14 to 19 in.  Adjustable lower leg support  Single or double lower leg support strap  Adjustable stump support</p>
<p><b>Frame</b></p> <p>Aluminum tube.</p>	<p><b>Folding foot supports</b></p> <p>Standard or oversized  Adjustable angle and depth, standard or oversized format  Adjustable full-width or fixed  Heel support strap  Bumper with castors</p>
<p><b>Seat</b></p> <p>Width: 14 to 20 in. (Prima 4)  Width: 18 to 24 in. (Prima R)  Depth: 14 to 20 in.  Front floor-to-seat height: 14 to 20 in.  Rear floor-to-seat height: 13 to 19 ½ in.  Flexible nylon seat sling with adjustable tension  2 in. seat cushion</p>	<p><b>Front wheels</b></p> <p>5, 6, 7 or 8 in. semi-solid tires  Air tires: 6 or 8 in.  High and low forks</p>
<p><b>Back support</b></p> <p>Angle adjustable from 85° to 110° in 5° increments  Back support post height from 14 to 23 in.  Back support post height with an 8° angle, from 14 to 23 in.  Flexible nylon upholstery with adjustable tension  Tension bar with head support anchor</p>	<p><b>Rear spoked wheels</b></p> <p>20, 22, or 24 in. diameter  Standard or high-pressure tires  Semi-solid tires  Threaded or quick-release axles  One-sided manual propulsion mechanism  Spoke guard</p>
<p><b>Head support</b></p> <p>Profiled upholstery  Height and angle adjustable head support</p>	<p><b>Hand rims</b></p> <p>Smooth anodized aluminum  Plastic coated  Foam  Non-slip  With oblique projections  Ergonomically designed</p>
<p><b>Arm support</b></p> <p>Short or long "U" type, retractable and removable, adjustable height from 8 to 12 in. or 10 to 14 in., telescopic rigid clothing guards</p> <p>Short or long "T" type, retractable and removable, height adjustable from 8 to 12 in. or 10 to 14 in., rigid clothing guards</p> <p>Short or long "L" type, swiveling, height adjustable from 8 to 12 in. or from 10 to 14 in., removable rigid clothing guard</p> <p>Short or long straight, profiled or gel profile comfort upholstery</p> <p>Tubular comfort upholstery ("L" type arm support)</p>	<p><b>Brakes</b></p> <p>Push, pull or one-sided  Telescopic brake handle extensions  Anti-reverse</p> <p><b>Others</b></p> <p>Auto pelvic positioning belt  Pelvic safety belt  Anti-tips with castors  Anchors for specialized transit  Reflective devices  Cane holder  Adapter for an amputee position  Rear wheel camber</p>

## 3. ADJUSTMENTS

	<p><i>Even if the bolts and screws are non-locking, after making any adjustments, and before using the wheelchair, check that all hardware is securely tightened. Check that the locking mechanisms are secure before using the wheelchair.</i></p>
	<p><i>Adjustments to your wheelchair should only be performed by health care professionals. Improper adjustments can cause injury and/or damage to the occupant, the assistant, the wheelchair, or the environment.</i></p>

### 3.1. LEG SUPPORT ASSEMBLY

#### 3.1.1. LENGTH ADJUSTMENT

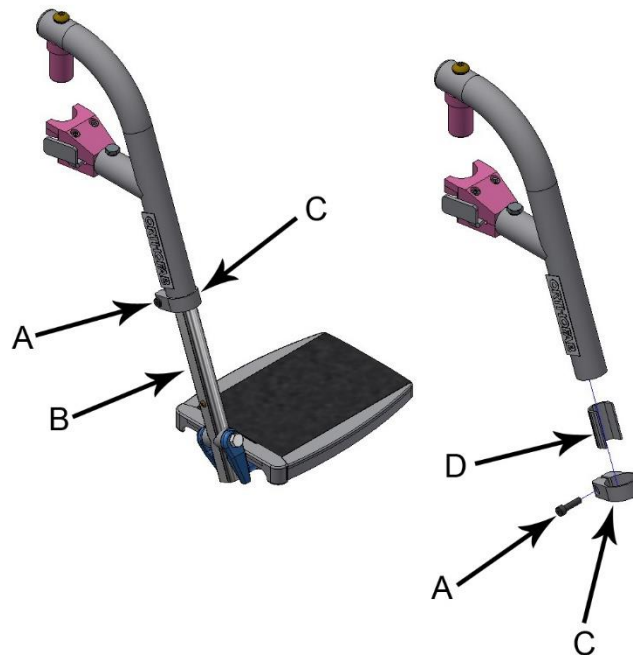

- 1 - Unscrew the hexagon socket screw (A) with a 5/32 in. Allen key.
- 2 - Slide the tube (B) to adjust the desired leg support length.
- 3 - Check that the spacer (D) is fully inserted in the stem.
- 4 - Reposition the clamping ring (C) and firmly tighten the screw (A).

## 3.1.2. CHANGING THE ANGLE OF THE ADJUSTABLE ANGLE FOOT SUPPORT, SINGLE AND FULL WIDTH

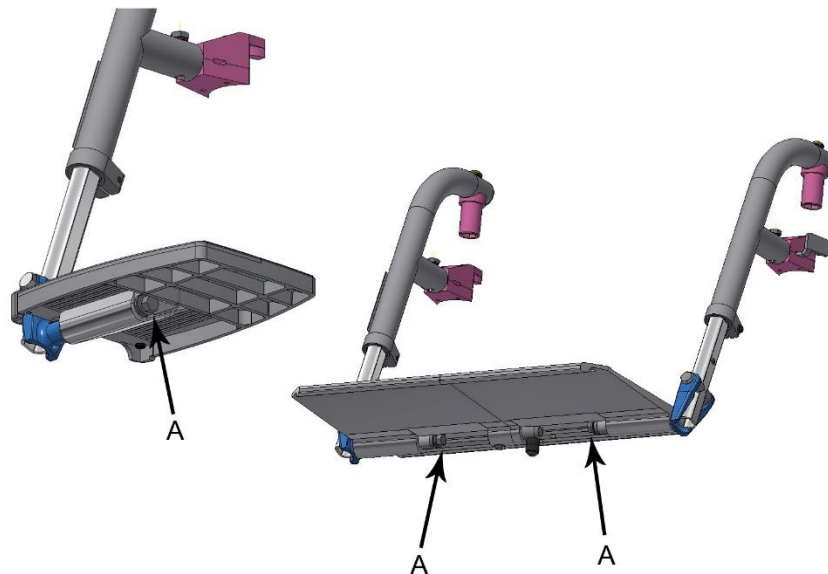

- 1 - Loosen the screws (A) with a 10 mm open-end wrench.
- 2 - Reposition the plates at the desired angle and firmly tighten the screws (A) (140 psi).

## 3.1.3. CHANGING THE POSITION (DEPTH) OF THE ADJUSTABLE ANGLE PLATE

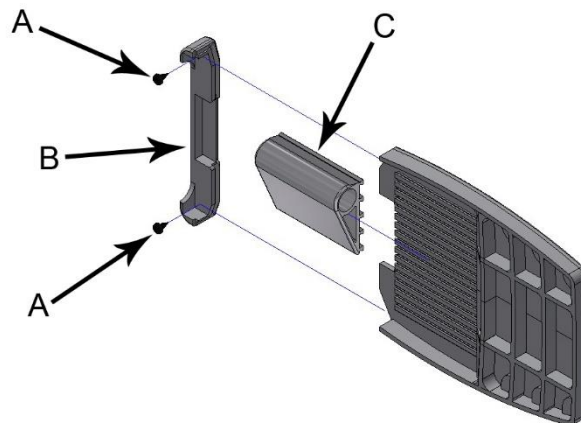

- 1 - Unscrew the 2 Phillips screws (A) and remove the end cap (B).
- 2 - Pull the plate to release it from the plate support (C).
- 3 - Reposition the plate to the desired depth and replace the end cap (B) and screws (A).

## 3.1.4. RETRACTING AND REMOVING THE LEG SUPPORT ASSEMBLY

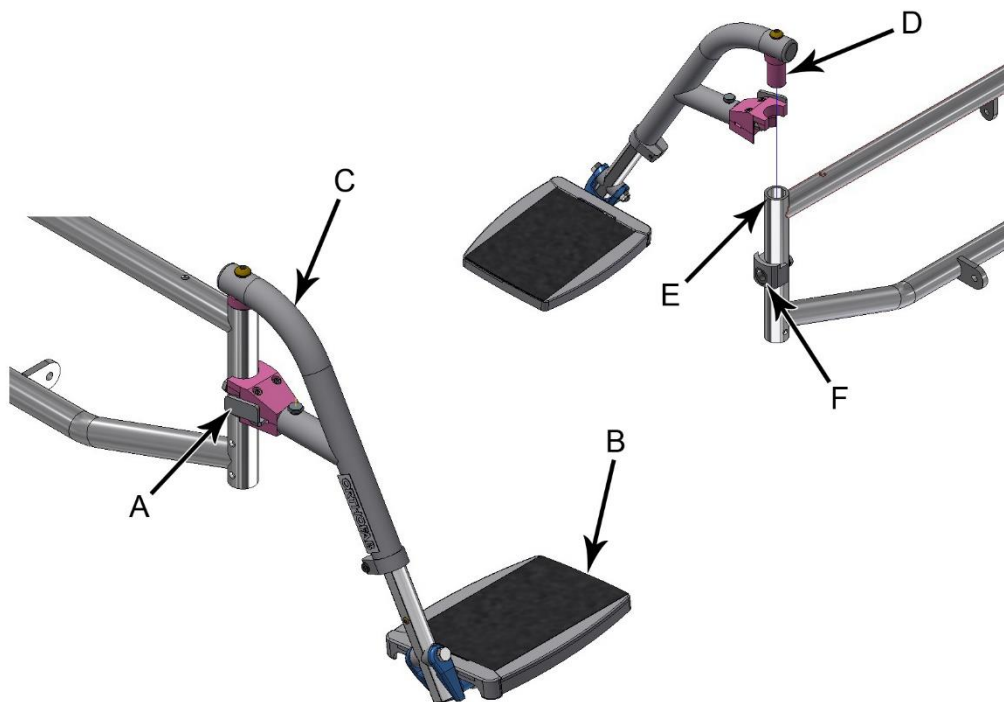

### RETRACTING THE LEG SUPPORTS

- 1 – Fold down the plates (B).
- 2 – Press the release (A) and rotate the stem (C) towards the outside or inside of the wheelchair.

### REMOVING THE LEG SUPPORTS

- 1 – Swing the leg support towards the outside of the wheelchair and lift the stem (C) to remove the leg support assembly.
- 2 – To replace the leg support, rotate it 90° in relation to the seat and insert the pivot (D) into the base (E). Then, rotate the leg support toward the locking mechanism (F) to lock it in place.



***Lifting the wheelchair by the leg support assemblies can be dangerous.***

NOTE<sup>1</sup>: It is best to fold down the foot support before retracting the leg support.

NOTE<sup>2</sup>: Always check that the front wheels are in forward position.

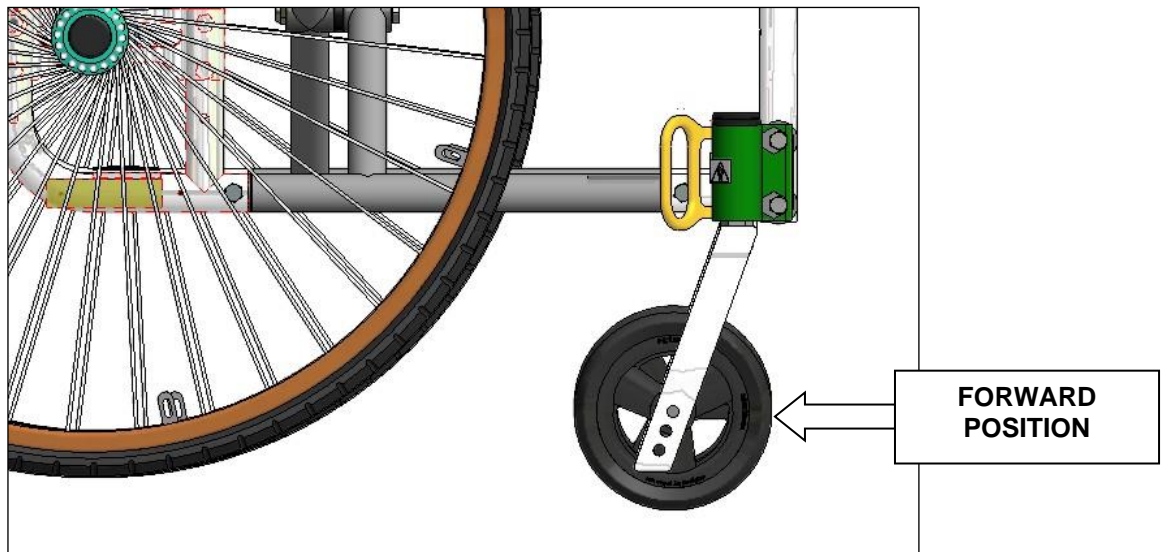

Figure 30-E: Retracting, wheels in forward position.

### 3.1.5. TWO-PIECE FULL-WIDTH PLATE

For full-width plate, fold down the plate with the anchor rod (A) (see Figures 2-A and 2-B).



Figure 2-A : Full-width plate

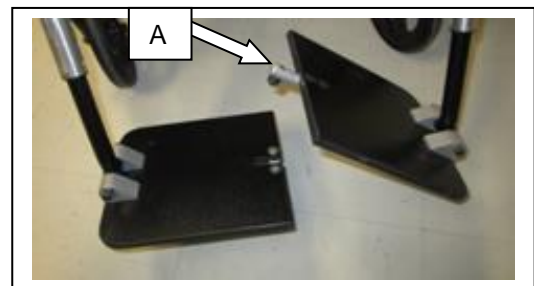
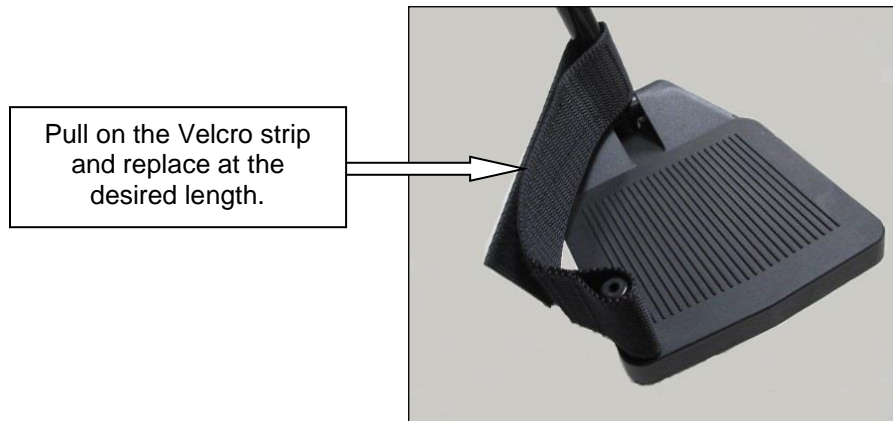

Figure 2-B: Full-width plate



## 3.1.6. DEPTH ADJUSTMENT OF HEEL SUPPORT STRAP



**Figure 3: Adjusting the heel support strap.**

## 3.1.7. ADJUSTING THE FLAT PADDED LOWER LEG SUPPORT

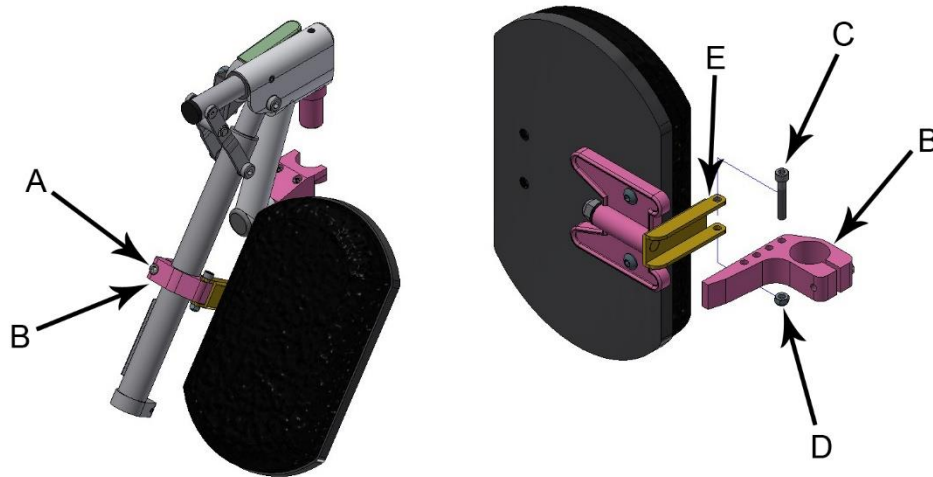

### HEIGHT

- 1 – Loosen the hexagon socket screw (A) with a 3/16 in. Allen wrench.
- 2 – Place the bracket (B) at the desired height and firmly tighten the screw (A).

### DEPTH

- 1 – Remove the screw (C) and the nut (D) with a 4 mm Allen key and an 8 mm open-end wrench.
- 2 – Move the lower leg support (E) into one of the holes of the bracket (B).
- 3 – Replace and tighten the screw (C) and the nut (D).

## 3.2. ARM SUPPORT

### 3.2.1. ADJUSTING THE REMOVABLE T-SHAPED ARM SUPPORT

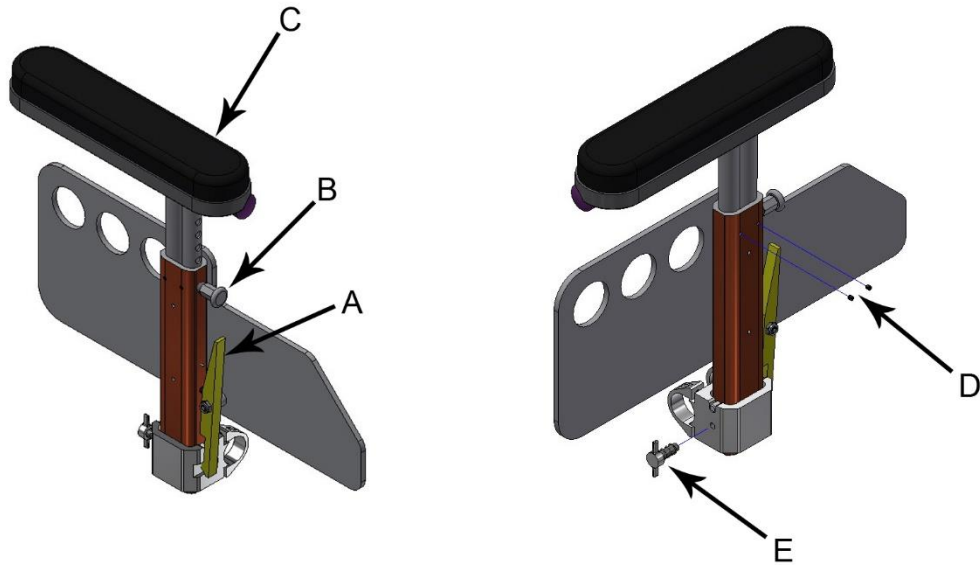

#### TO REMOVE THE ARM SUPPORT

- 1 – Tighten the screw (E) to secure the arm support assembly.
- 2 – To remove the arm support, press the lever (A), then remove the assembly (make sure the screw (E) is not tightened).

#### HEIGHT ADJUSTMENT

- 1 – Tighten the screws (D) with a 1/16" Allen wrench to lock the height adjustment.
- 2 – To adjust the height of the arm support, pull the plunger (B) and adjust the support (C) to the desired height. Then, let go of the plunger (make sure the screws (D) are not tightened).

## 3.2.2. ADJUSTING THE REMOVABLE AND FOLDABLE U-SHAPED ARM SUPPORT

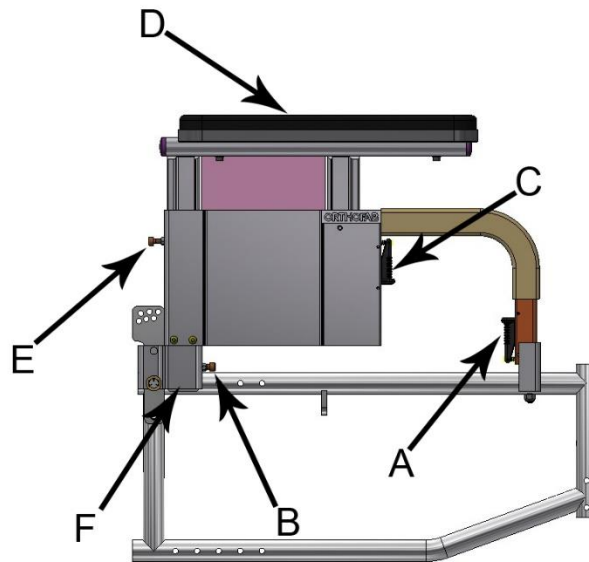

### TO FOLD DOWN AND REMOVE THE ARM SUPPORT

- 1 – To fold down the arm support, press the release (A) and rotate the assembly towards the back of the wheelchair.
- 2 – You can lock the removable assembly rest with the screw and locknut (B). Tighten the screw with a 4 mm Allen wrench, then lock it with the lock nut, using an 8 mm open-end wrench.
- 3 – To remove the arm support, fold down the arm support as seen in step 1, then remove the base assembly (F) (making sure the screw and lock nut (B) are not tightened).

### HEIGHT ADJUSTMENT

- 1 – You can lock the height adjustment with the screw and the lock nut (E). Tighten the screw with a 4 mm Allen wrench, then lock it with the lock nut, using an 8 mm open-end wrench.
- 2 – To adjust the height of the arm support, press the release (C) and adjust the support (D) to the desired height, then let go of the release (making sure the screw and the lock nut (E) are not tightened).

## 3.2.3. ADJUSTING THE REMOVABLE T-SHAPED ARM SUPPORT

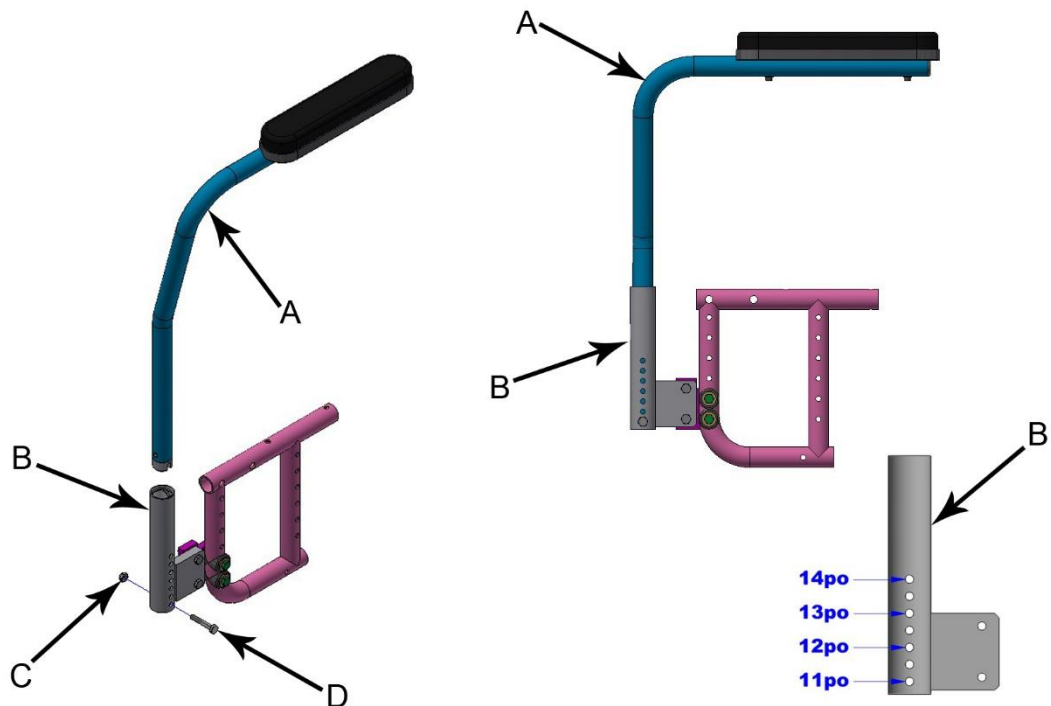

### PIVOTING AND REMOVING THE ARM SUPPORT

- 1 – To pivot the arm support, pull the arm support (A) up just enough to release it from the screw (D) and rotate it out of the wheelchair.
- 2 – To remove the arm support, simply pull on the arm support (A) until it comes off the base (B).

### HEIGHT ADJUSTMENT

- 1 – To adjust the arm support height, change the position of the screw (D). Using two (2) *7/16 open-end wrenches*, remove the screw (D) and the nut (C), then replace them in the hole corresponding to the desired height.

## 3.3. ANGLE-ADJUSTABLE BACK SUPPORT

### 3.3.1. BACK SUPPORT ANGLE ADJUSTMENT

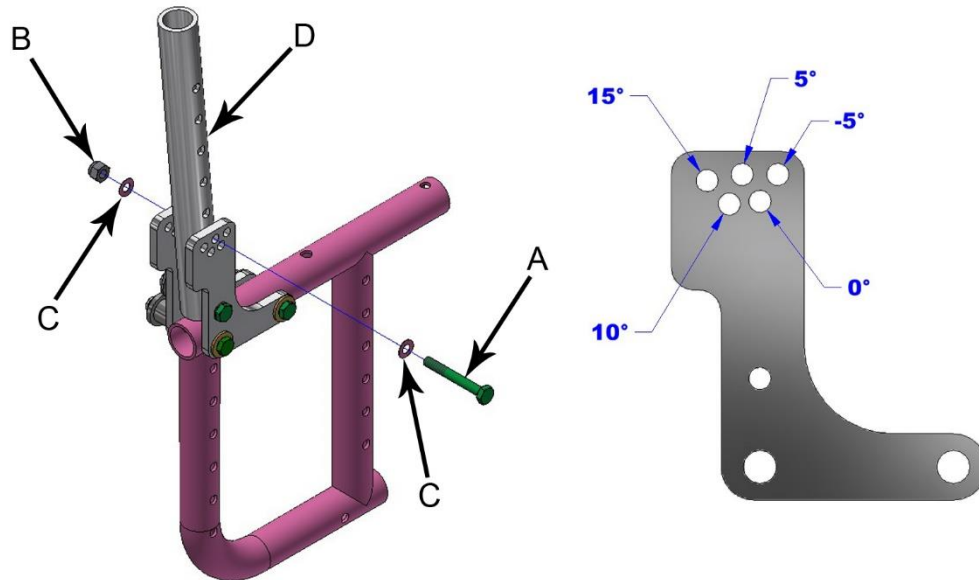

- 1 – Using a  $7/16$  in. open-end wrench, loosen and remove the screw (A), the nut (B) and the washers (C).
- 2 – Adjust the back support (D) to the desired angle, then place the hardware in the hole corresponding to the chosen angle.



**Once screws (A) are removed, the back support can be folded completely backwards.**

## 3.3.2. CHANGING BACK SUPPORT HEIGHT

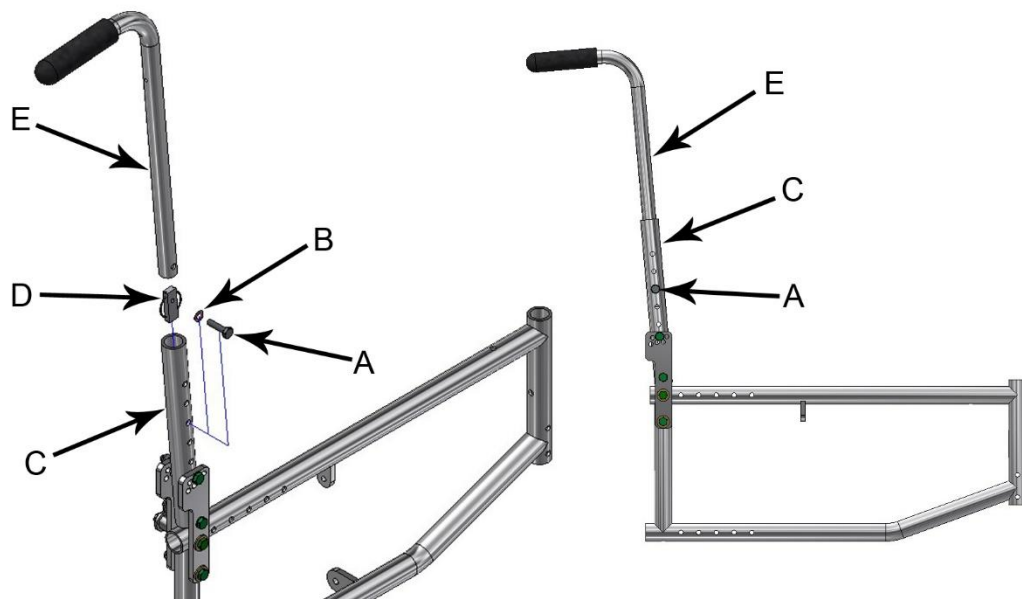

1 – Loosen the screw (A) with a 7/16 in. wrench.

2 – Choose the desired height by aligning the threaded hole of the spacer (D) of the back support (E) with a hole of the back support (C), then firmly tighten the screw (A), making sure the washer (B) is in place.

## 3.4. INSTALLING THE BACK SUPPORT TENSION BAR

To stiffen the back support, you can install a tension bar. To do this:

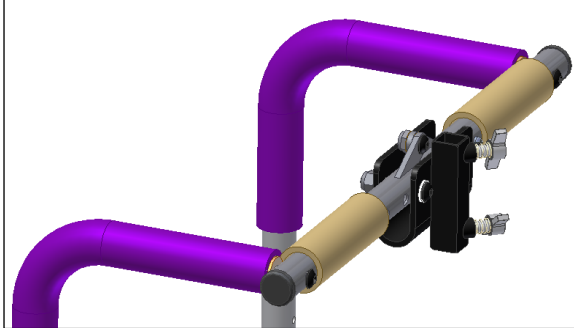

**Figure 11-A: Installed back support tension bar with back support anchor.**

1. Cut the rubber handle evenly with the end of the back support posts;
2. Insert the spacer clamp (C) onto the back support post tube (see Figure 11-B);
3. Using a 4 mm Allen wrench, insert screw (B) into the spacer clamp (C), then insert screw (A) into the end of part (C) to complete the assembly.
4. Once the assembly is complete, it should resemble Figure 11-A (the rubber handle should completely cover screw (B); the bar should fold downward).

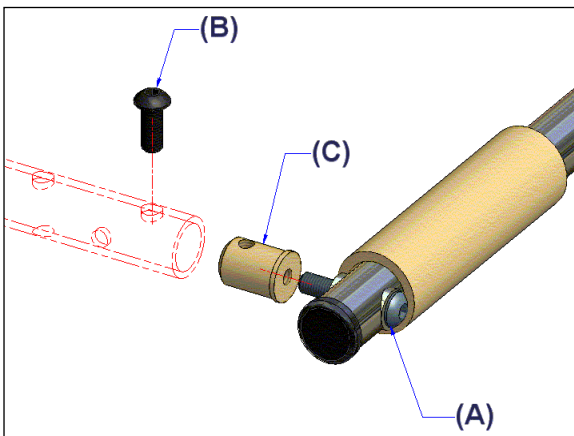
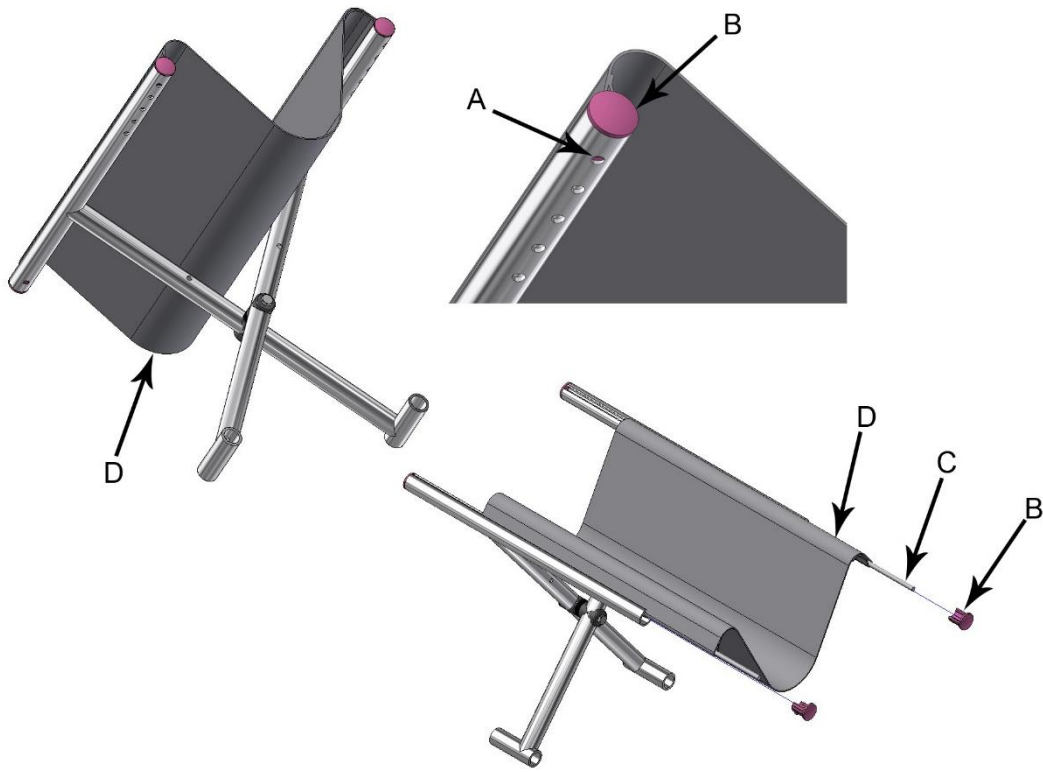

**Figure 11-B: Tension bar attached to back support.**



## 3.5. SEAT

### 3.5.1. REMOVING THE SEAT SLING



- 1 – Close the wheelchair to release the tension on the seat sling (D).
- 2 – Use a pointed object (punch, Phillips screwdriver, etc.) to push on the plug latch (B) in the hole (A).
- 3 – Remove the plugs (B), then pull on the seat sling (D); the seat sling and the rods (C) will slide into the braces.



***When reinstalling the seat sling, make sure to align the retaining latch into the mounting hole.***

## 3.5.2. ADJUSTING THE SEAT SLING TENSION

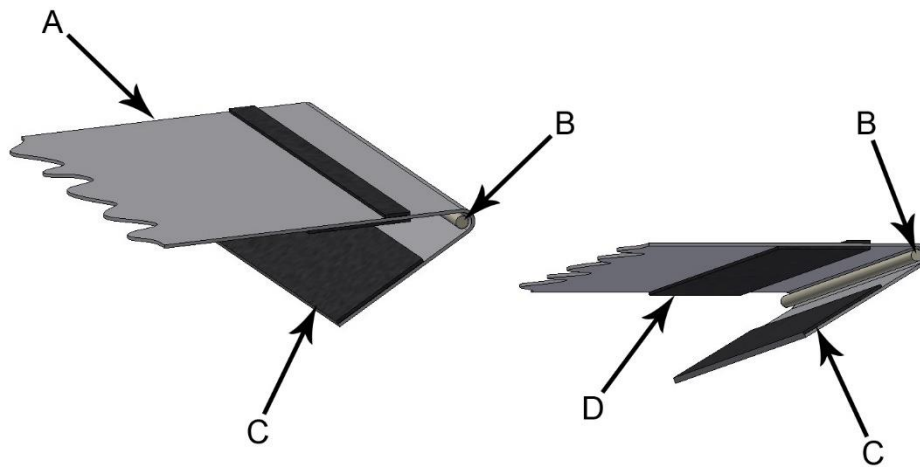

1 – Remove the seat sling (A) as in point 4.4.1.

2 – Detach the flap with hook and loop fastener (C), then reposition it on the part (D) to adjust the tension.

3 – To replace the seat sling (A) and rods (B) in the crosspieces as in point 4.4.1.



***When reinstalling the seat sling, make sure to align the retaining latch into the mounting hole.***

## 3.6. FLOOR-TO-SEAT HEIGHT AND CENTRE OF GRAVITY

### 3.6.1. FRONT FLOOR-TO-SEAT HEIGHT ADJUSTMENT.

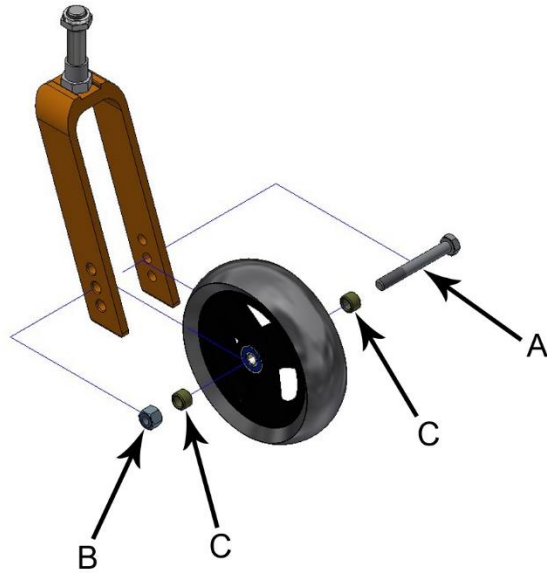

- 1 – Using two (2) 8 mm open-end wrenches, remove the screw (A) and the nut (B).
- 2 – Reposition the wheel and the spacers or washers (C) in another position.
- 3 – Replace the screw (A) and the nut (B) in the new hole and screw in place. Do not overtighten, the wheel must be able to turn freely.

## 3.6.2. REAR FLOOR-TO-SEAT HEIGHT ADJUSTMENT.

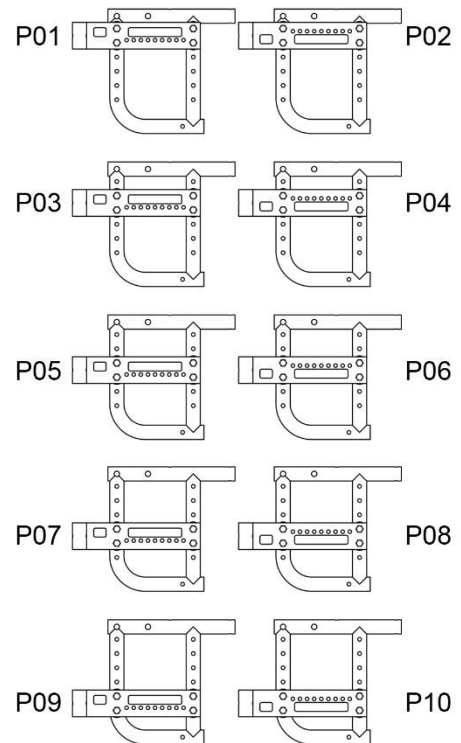
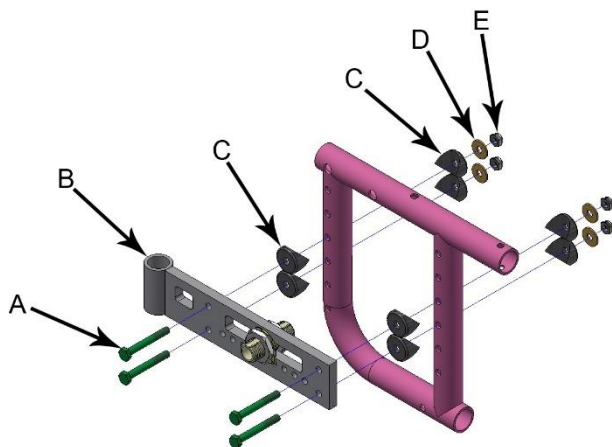

- 1 – Remove the rear wheels from the wheelchair.
- 2 – With two (2) 7/16 in. flat wrenches, loosen the 4 screws (A) and 4 nuts (E).
- 3 – Reposition the multi-position plate (B) with the hardware (A) (C) (D) (E) to the desired position. If you switch from an even-numbered position (P02, P04, etc.) to an odd-numbered position (P01, P03, etc.) and vice versa, you must reverse the plates, placing the right plate on the left and the left on the right.
- 4 – Firmly tighten the 4 screws (A) and 4 nuts (E).
- 5 – Check that the 2 plates (B) are in the same position (P01, P02, P03, etc.) on each side of the wheelchair, then put the rear wheels back on the wheelchair.



**Once the adjustment is complete, you must adjust the locking brakes and anti-tips.**

## 3.6.3. ADJUSTING THE CENTRE OF GRAVITY

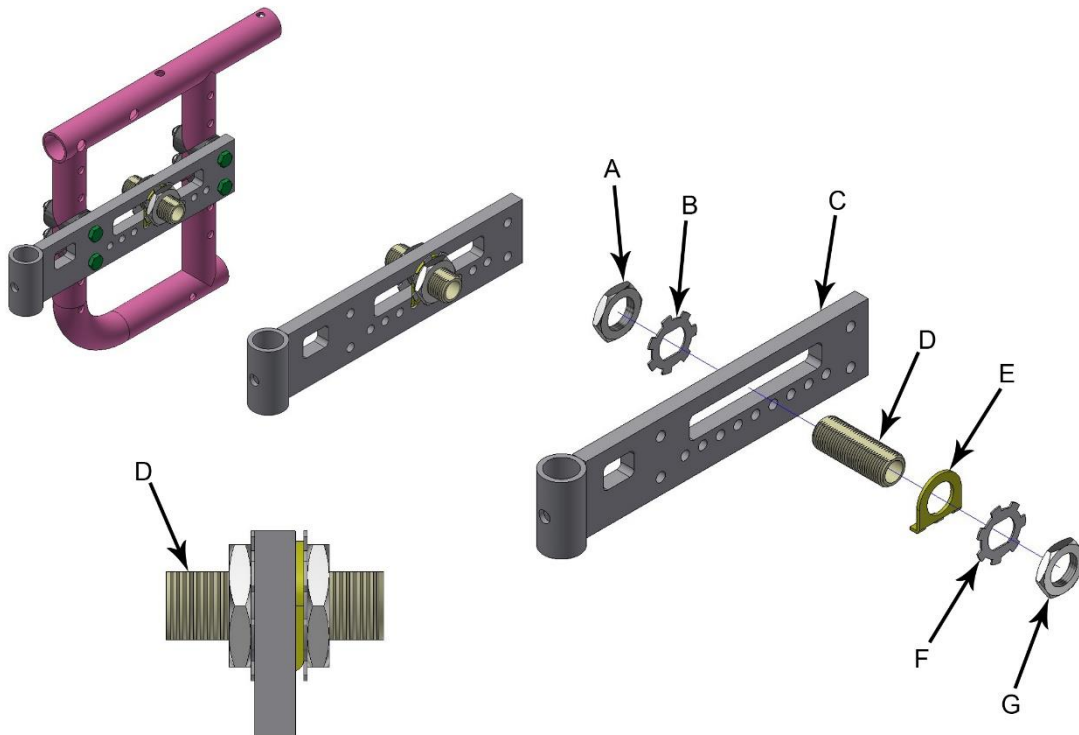

- 1 – Unfold the lock washer notch (F), then loosen and remove the nut (G) and washer (F), using a 1 1/8 in. open-end wrench.
- 2 – Remove the remaining adjustment spacer assembly (A) (B) (D).
- 3 – Move the adjustment slider (E) to the desired position, then replace the parts removed in step 2.
- 4 – Replace the lock washer (F) and tighten the nut (G) with a 1 1/8 in. torque wrench to 30 lb-ft. Use pliers to bend the lock washer notch (F) over the nut (G).
- 5 – Make the same adjustment on both sides of the wheelchair.



***The further back the wheel is positioned, the more stable the chair will be. These positions should be determined by the prescribing physician or clinical staff.***



***Once the adjustment is complete, you must adjust the locking brakes and anti-tips, according to instructions.***

## 3.7. REAR WHEELS

### 3.7.1. THREADED AXLES

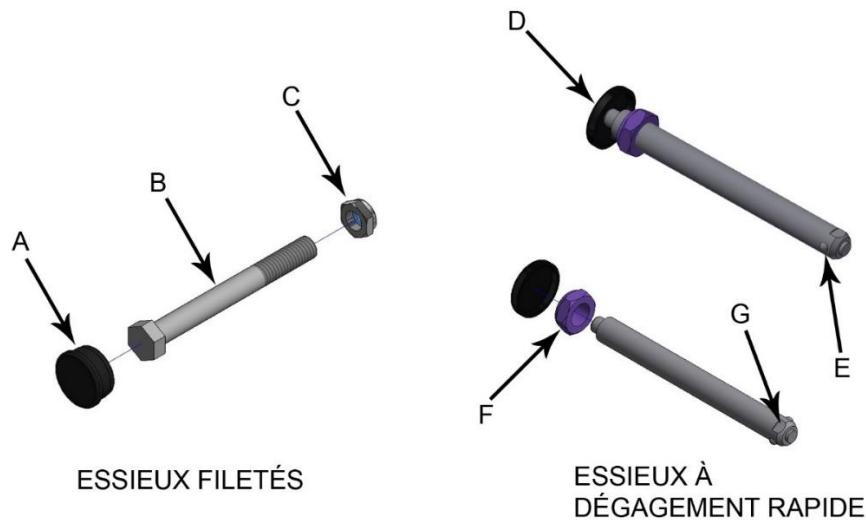

#### THREADED AXLES

1 – To remove the wheel, remove the cap (A) from the wheel hub, then loosen the screw (B) using a 3/4 in. wrench and the nut (C), using a 3/4 in. wrench.

2 – To reassemble the wheel, re-tighten the screw (B) and the nut (C). Do not overtighten the assembly as the wheel will have trouble turning, then replace the cap in the wheel hub.

#### QUICK-RELEASE AXLES

1 – To remove the wheel, hold down the button (D) and pull the wheel towards you by the centre;

2 – Follow the same procedure to install the wheel, checking that the axle is locked in place by the stop pins (E).

NOTE: If the axle does not lock, it may need to be adjusted. To do this:

1 – Remove the quick-release axle.

2 – Using a 7/16 in. open-end wrench, hold the end of the axle (G), and use a 3/4 in. open-end wrench to slightly tighten or loosen the nut (F).

3 – Reinsert the axle into the wheel and test it (always leave about  $\pm 1/64$  in. of play to the side once the axle is locked).



**Check that the stop pins on the quick-release axles are fully unlocked before using the wheelchair. The stop pins must protrude from the wheel axle spacer for a secure lock. Keep the stop pins clean.**

## 3.7.2. WHEEL WIDTH ADJUSTMENT

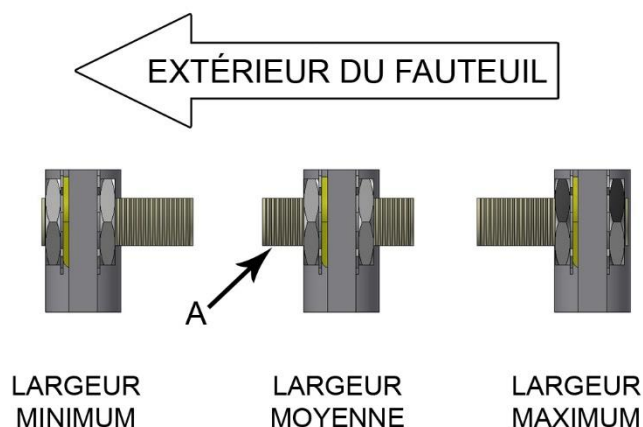

1 – Remove the adjustment spacer assembly, as in point 4.5.3.

2 – Replace the adjustment spacer assembly as in point 4.5.3, but during assembly, screw or unscrew the spacer (**A**) to move the wheels closer to or further away from the wheelchair.

## 3.7.3. AIR TIRE PRESSURE

To guarantee your wheelchair's optimum mobility, the tire pressure should be checked weekly.

**NOTE:** Check that the inflator will not damage the tire if the pressure is higher than recommended for the tire.

20 in. standard tire pressure	65 psi
20 in. high tire pressure	110 psi
22 in. standard tire pressure	65 psi
22 in. high tire pressure	110 psi
24 in. standard tire pressure	75 psi
24 in. high tire pressure	110 psi

## 3.8. FORK BRACKET

### 3.8.1. PERPENDICULAR FORK ALIGNMENT

To maintain a linear trajectory of the wheelchair and to facilitate turning, it is important to ensure a 90° angle between the ground and the axis of the fork stem. To make this adjustment, follow the instructions outlined below.

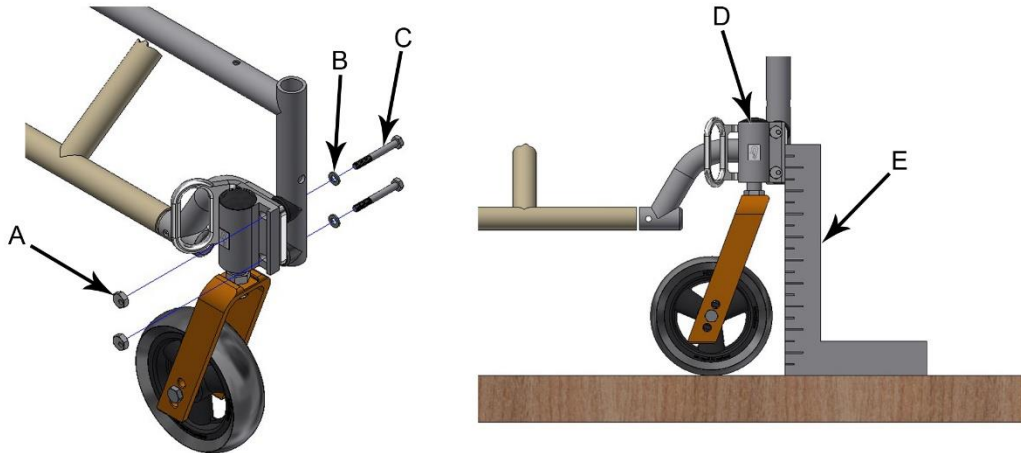

- 1 – Use a 10 mm open-end wrench to loosen the screws (C) and release the hex spacers (A) from the fork bracket extrusion (D). 2 – Leave the screws (C) and washers (B) in place to hold the fork bracket assembly.
- 3 – Use a square (E) to find the correct configuration of the hex spacers (A). To do this, first install one hex spacer (A), then the second. The bracket (D) should be perpendicular to the ground.
- 4 – Firmly tighten the screws (C) in the hexagonal spacers (A).



## 3.8.2. FORK BRACKET ORIENTATION

For reduced clutter and easier handling, it is best to mount the fork brackets toward the rear. However, with shallow seat depths, certain front and rear wheel diameter configurations can create interference between front and rear wheels or the front frame. In such cases, the fork brackets should be mounted forward, reversing them; i.e., left bracket to right and right bracket to left.

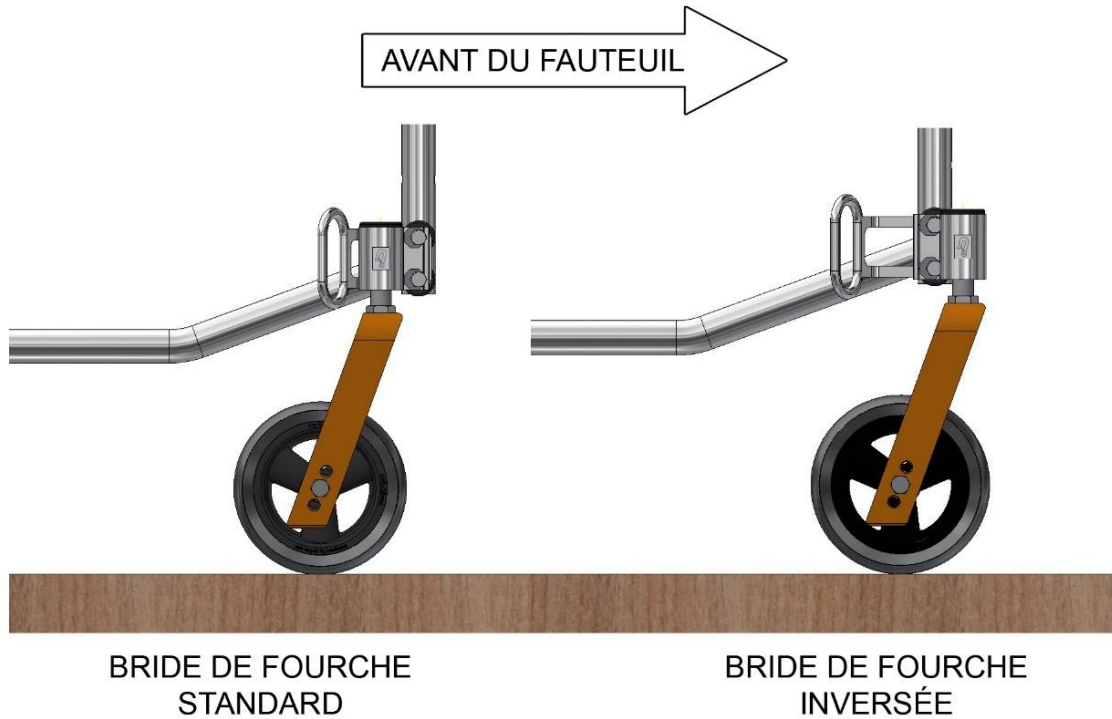

## 3.9. LOCKING BRAKES

### 3.9.1. BRAKE POSITION ADJUSTMENT

Brake adjustment is necessary depending on the level of tire wear or whenever the position of the rear wheels is changed. Check for proper tire pressure before adjusting the brakes.



1 – Slightly loosen the brake bracket screw (**A**) with a 13 mm open-end wrench (for push or pull brakes), or a 6 mm Allen wrench (for one-sided brakes), until the brake rod (**C**) can rotate slightly, and the bracket (**B**) can slide onto the frame tube.

2 – Move the brake rod (**C**) and bracket (**B**) forward or backward on the frame tube until the brake brace (**D**) is between  $\frac{1}{4}$  and  $\frac{1}{2}$  in. from the tire when the brake is in the open position. Also check that the brake brace (**C**) is perpendicular to the tire.

3 – Once brakes are at the correct distance, firmly tighten the brake bracket screws.

The brake is at optimal efficiency when there is a  $\frac{1}{4}$  to  $\frac{1}{2}$  in. space between the tire and the brake brace, with the brake open.

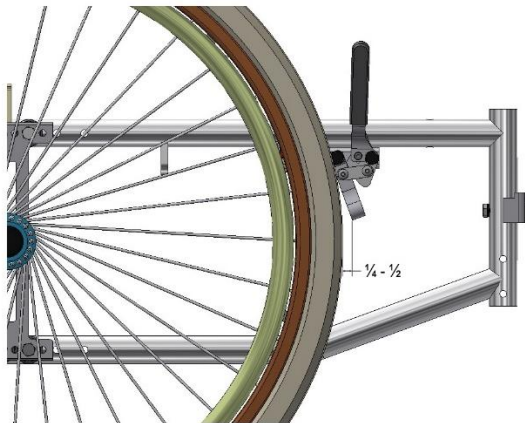

FREIN OUVERT



FREIN FERMÉ



***You can have a standard push, pull or one-sided brake, but some specific wheelchair configurations require pull brakes.***

***To activate the push brakes, push the brake lever forward.  
To activate the pull brakes, pull the brake lever backwards.  
To activate the one-sided brake, push the lever to either the left or right side of the wheelchair.  
The adjustment method for the brake position is the same for both brakes.***

## 3.9.2. CHANGING OR INSTALLING A BRAKE LEVER EXTENSION

1. Install extension guides (E) on each side of brake lever (A);
2. Place the spring (D) provided with the extension (F) into hole (B).
3. Insert the pin (C) into the hole (B) by compressing the spring (D);
4. While holding the pin (C) inside the hole (B), slide the extension (F) so that it covers the entire assembly. **Caution:** This assembly may be difficult to complete the first few times, so be careful not to lose the pin (C).

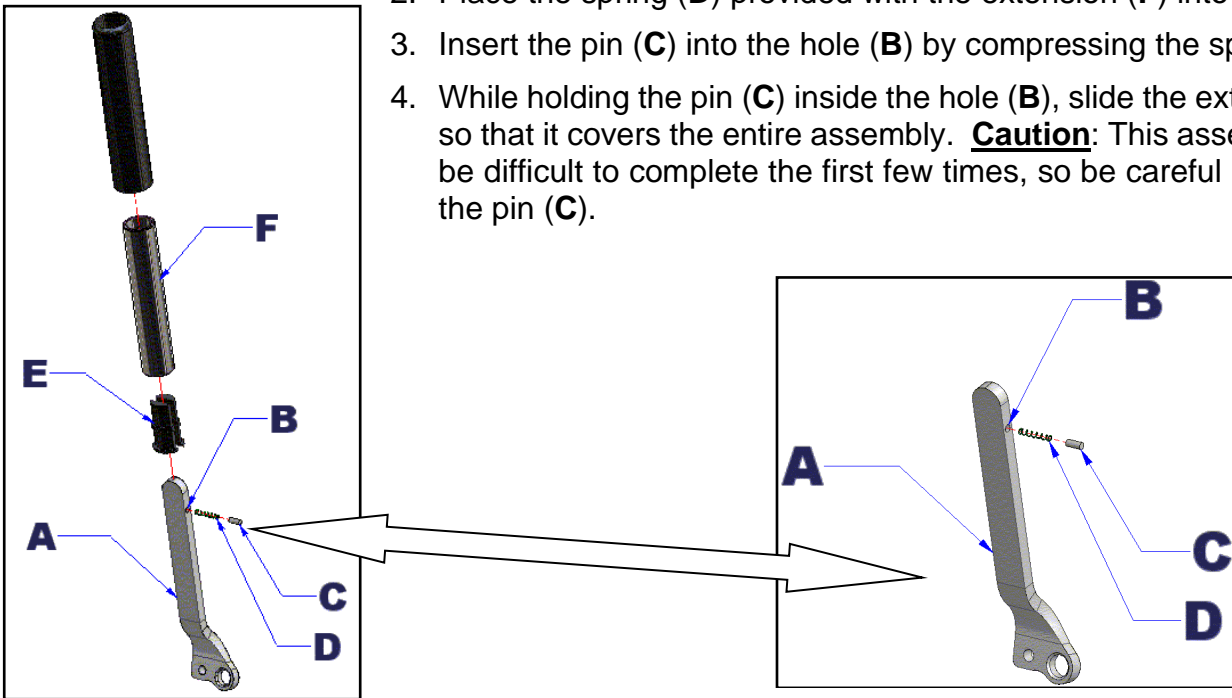

Figure 19: Telescopic extension installation.

## 3.9.3. CHANGING THE BRAKE LEVER ANGLE (push brake only)

**NOTE:** You can adjust the angle of the brake lever.

To do this:

- Loosen the screw (B) with a *1/8 in. hex key*, then rotate the lever to the desired position (see Figure 20);
- Replace the (B) screws and tighten firmly. Do not forget the lock washer.

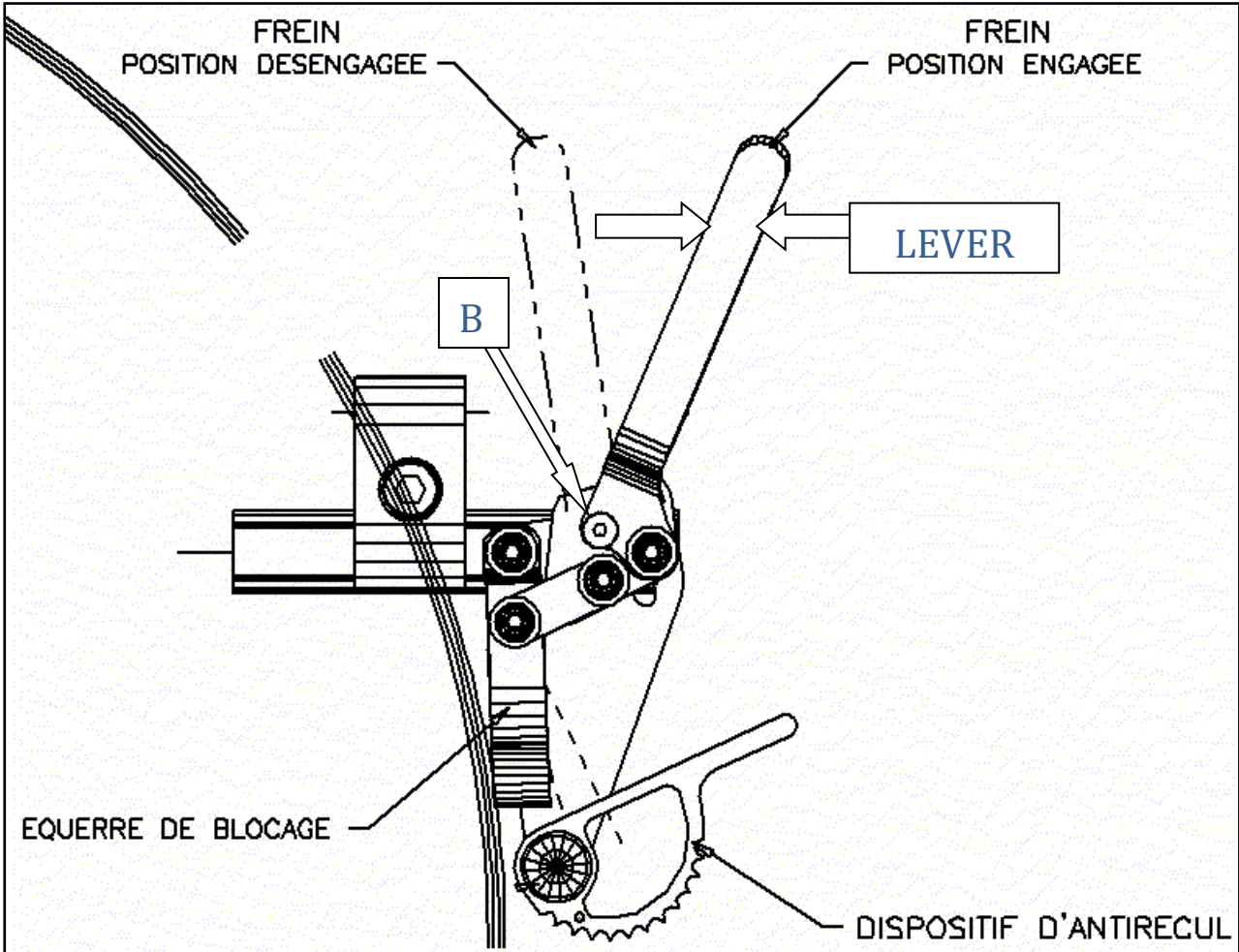

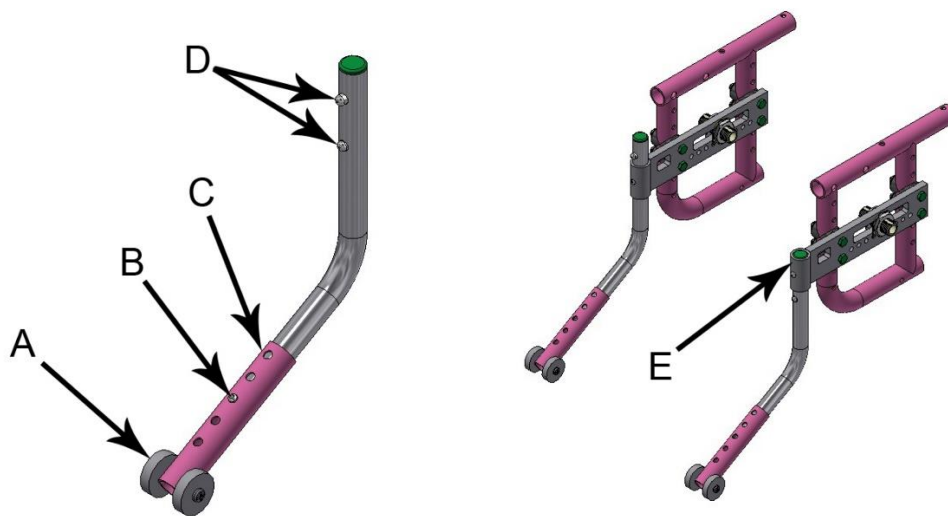

Figure 20: Brake lever angle adjustment.

## 3.10. ANTI-TIPS

	<p><i>A maximum clearance of 1 ¾ in. between the anti-tip rollers and the ground must always be maintained.</i></p>
	<p><i>If the floor-to-seat height or the rear wheel size has been changed, the anti-tips must be adjusted to a clearance of 1 ¾ in. between the bottom of the roller and the ground.</i></p>

### 3.10.1. HEIGHT ADJUSTMENT OF ANTI-TILT DEVICES



1 – The anti-tips can be adjusted in two ways: by the telescopic tube (C) or the anti-tip base (E). Push the spring button (B) and slide the tube (C) up or down, and/or fix the anti-tip in its base (E) with one of the 2 spring buttons (D).

2 – Find a position that allows a clearance of 1 ¾ in. between the anti-tip rollers (A) and the floor.

	<p><i>The anti-tips should be fully engaged and the spring buttons should protrude from the adjustment holes.</i></p>
-------------------------------------------------------------------------------------	-----------------------------------------------------------------------------------------------------------------------

## 3.11. WHEELCHAIR HANDLING

### 3.11.1. TO OPEN THE WHEELCHAIR

Position yourself to the side of the wheelchair. Using both hands, push down on both seat rails as shown in Figure 24, and push until they rest in the (A) brackets provided; or use one hand to alternately push down on the seat rails.



**Figure 24: To open the wheelchair.**

If your wheelchair has a back support tension bar, pull up the two (2) tension bars until they click into place.

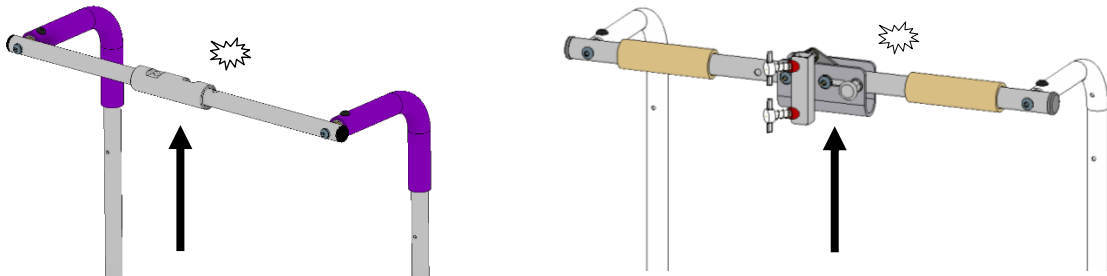

**Before sitting in the wheelchair, check that it is completely unfolded, then apply the brakes.**



**When opening the wheelchair, avoid placing your fingers between the seat rail and the frame.**

## 3.11.2. TO FOLD THE WHEELCHAIR

1. Raise the foot support, making sure to push the heel support straps forward, if necessary;
2. Remove the seat cushion;
3. Retract the lower leg supports, if applicable;
4. Fold the back support push bar, if applicable;
  - a. Without head support anchor, press the button, release the tube, and push down.

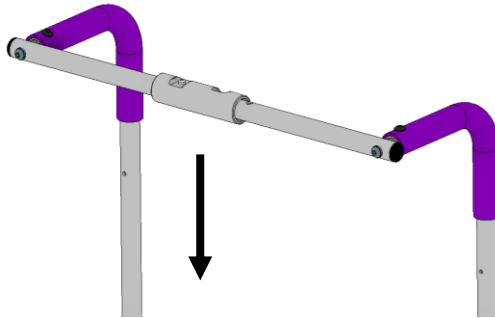

- b. With head support anchor, pull the release and push down.

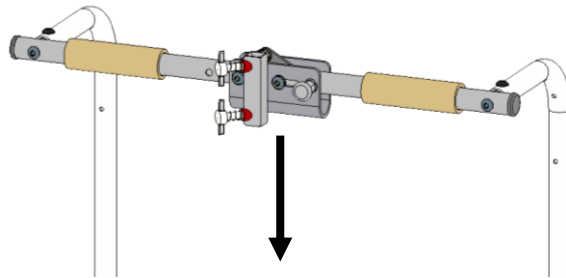

5. Grasp the handle on the seat sling and pull upwards until the wheelchair is completely folded (see Figure 25).



**Figure 25: To fold the wheelchair.**

## 3.12. HEIGHT AND DEPTH ADJUSTABLE HEAD SUPPORT



Turn the handle (A) to adjust the depth of the head support, then turn the two handles (B) to adjust the height (see Figure 26-A).

After selecting the head support height position, adjust the retaining ring (C) on the head support anchor (D) for a better fit, and to indicate the position when replacing the head support.

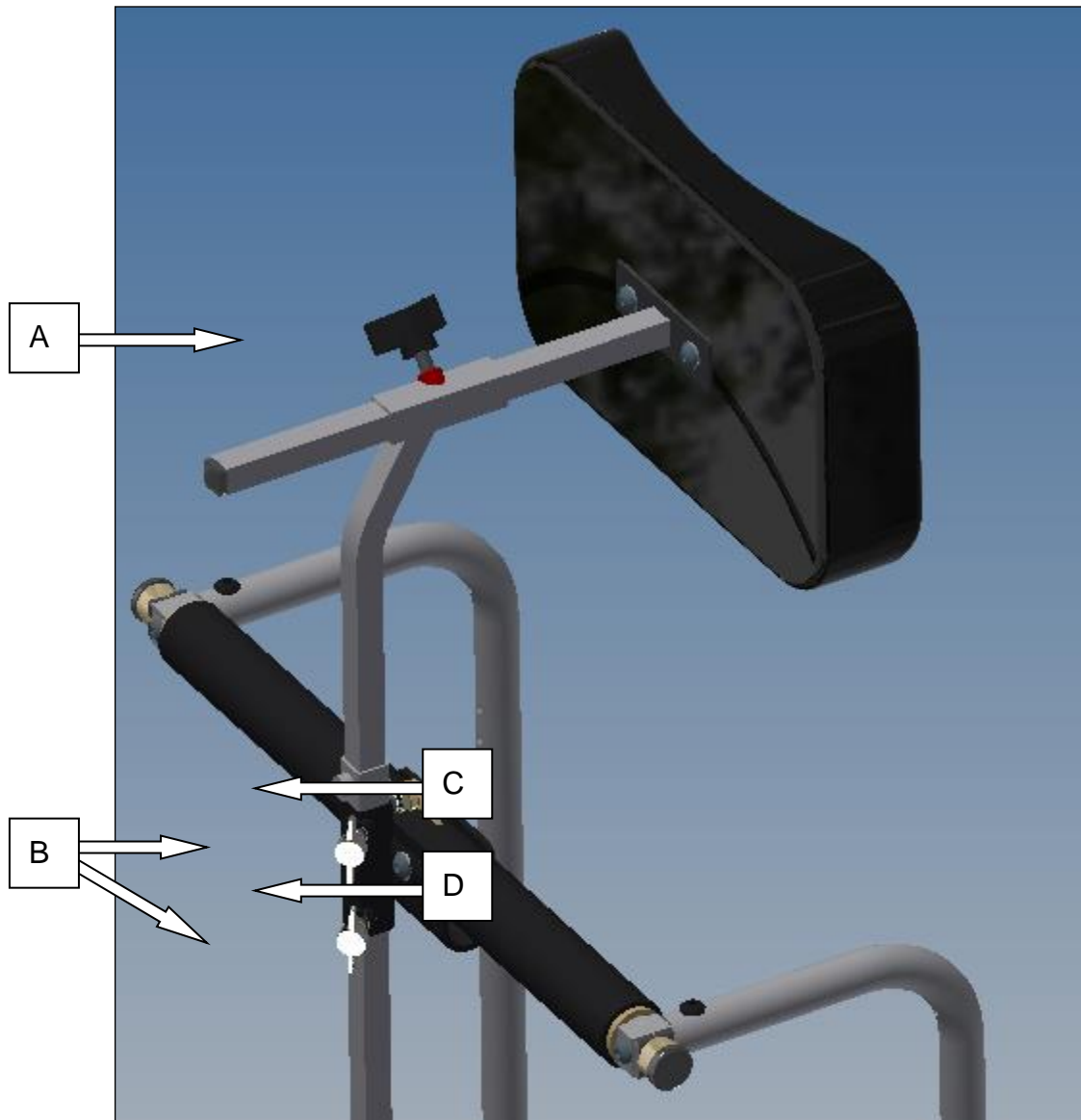

**Figure 26-A: Height and depth adjustable head support**

## 3.13. ADJUSTABLE TENSION BACK SUPPORT

The adjustable tension back support has a set of Velcro straps (A) to adjust the tension level. To adjust the back support, simply open the fabric flaps (B), adjust the straps to the desired tension and close the flaps, making sure to tighten them securely. The center straps can also be height-adjusted by repositioning the small Velcro envelopes (C) (see Figures 32-A and B).

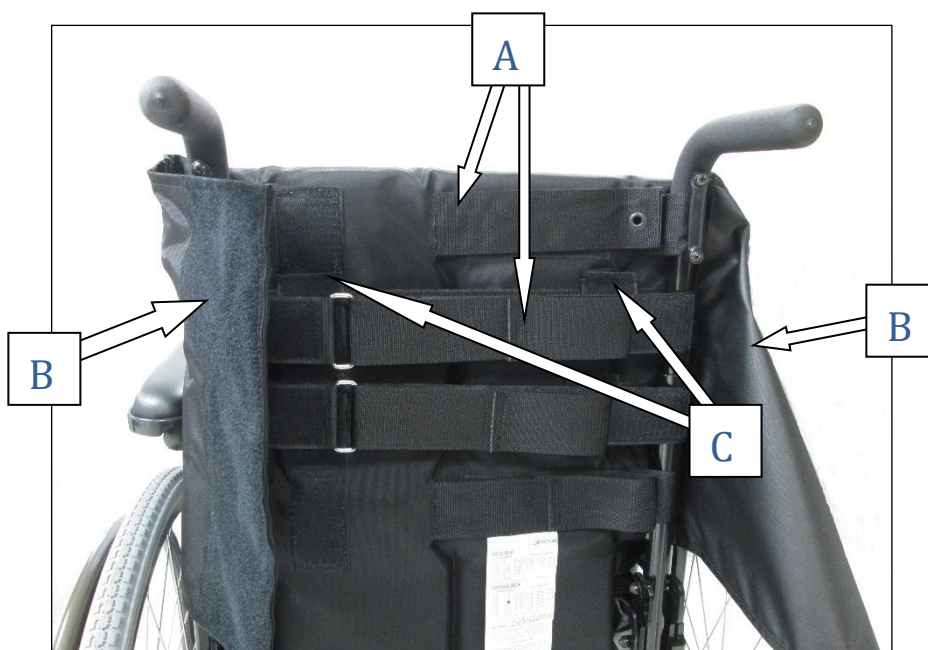

**Figure 32-A: Open adjustable tension back support.**

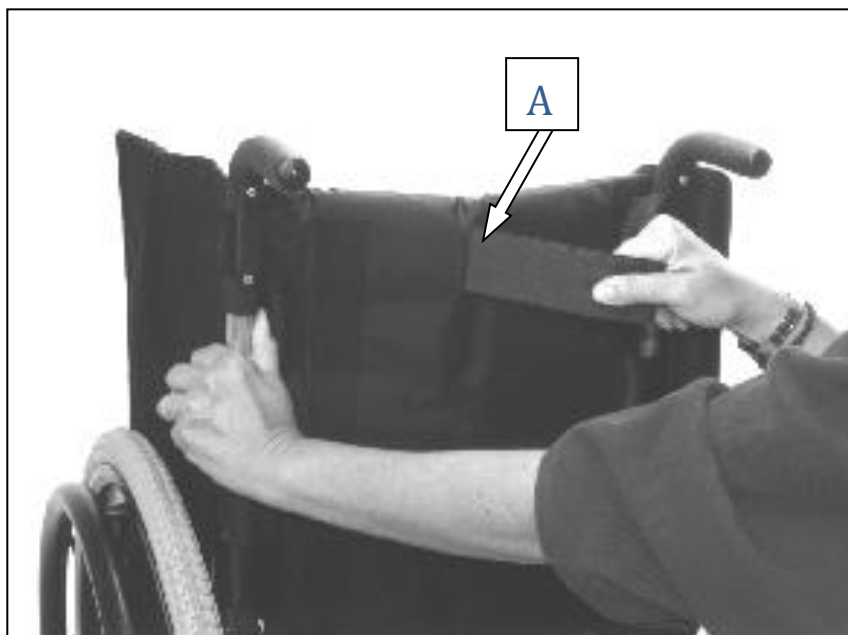
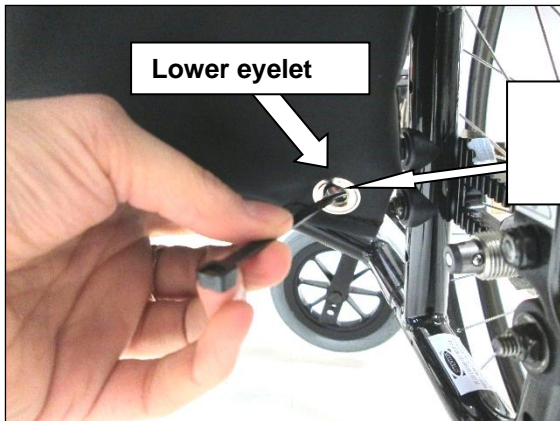

**Figure 32-B: Back support adjustable tension.**

After adjusting the straps, you must stabilize the lower flap of the soft back support.

To do this:

Use two plastic self-locking tie wraps to attach the lower flap of the back support from the lower eyelets to the front part of the rear frame of the manual wheelchair. This adjustment provides stability to the occupant's sacroiliac area while maintaining seat depth.



**Figure 32-C: Lower back support flap.**

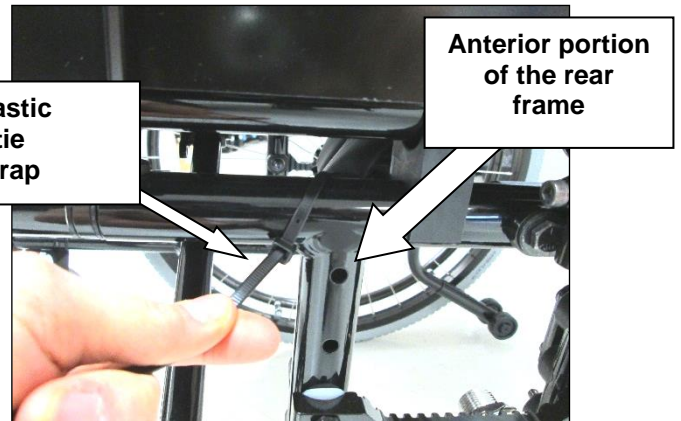
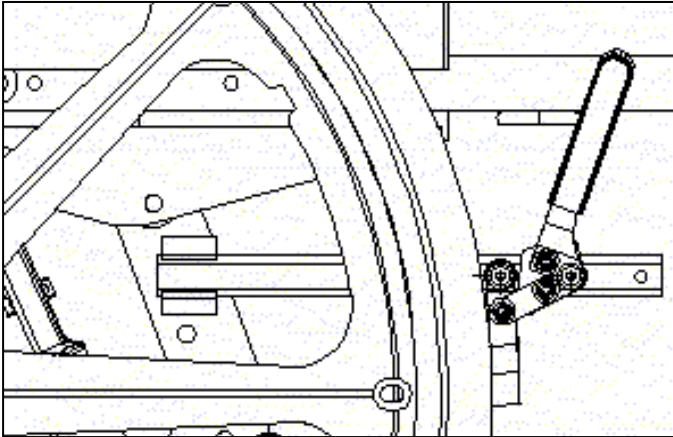

**Figure 32-D: Lower back support flap.**

## 3.14. LOCKING BRAKES

### 3.14.1. ENGAGING – RELEASING PUSH-TYPE BRAKES

**NOTE:** Reverse the lever action directions for pull-type brakes.



**Figure 34-A: Push brake ENGAGED.**

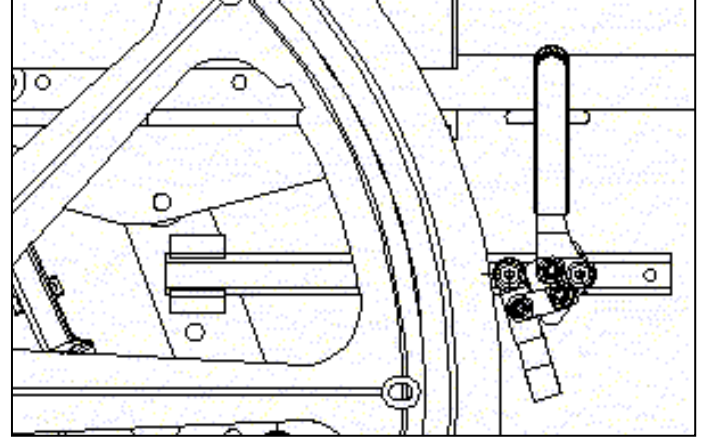

**Figure 34-B: Push brake DISENGAGED.**

- a) To engage the brakes, push forward on the lever (see Figure 34-A);
- b) To disengage the brakes, pull the brake lever towards you (see Figure 34-B).

**NOTE:** Inadequate tire pressure will render the brake ineffective.

### TELESCOPIC HANDLES

For easy access, the brake can be equipped with a lever extension.

- a) To extend the lever, pull up on the end (see Figure 35-A);
- b) To retract the lever, press down on the end (see Figure 35-B).

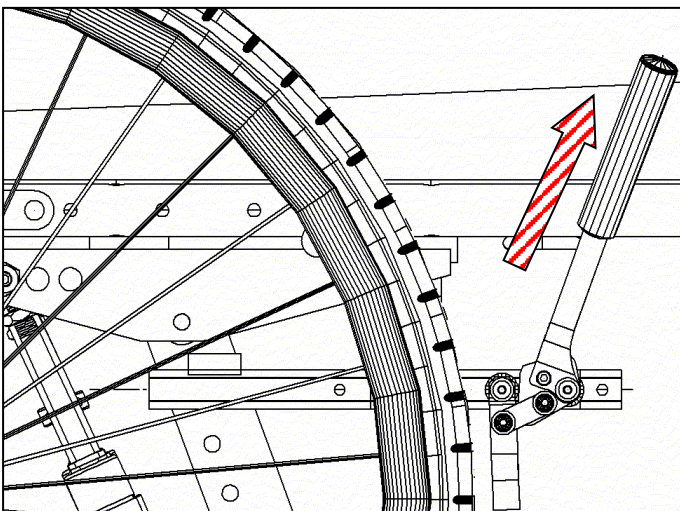

**Figure 35-A: Extended handle.**

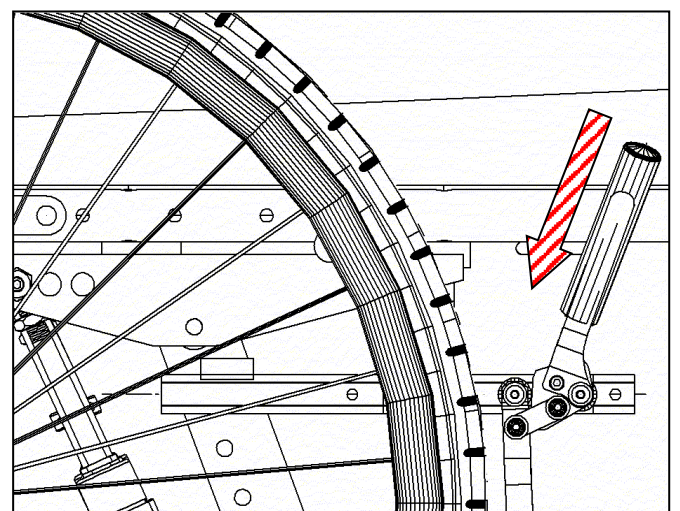

**Figure 35-B: Retracted handle.**

## 3.14.2. ENGAGING – RELEASING THE ANTI-REVERSE

To help you negotiate inclines, your wheelchair can be equipped with an anti-reverse mechanism that prevents the wheelchair from rolling backwards.

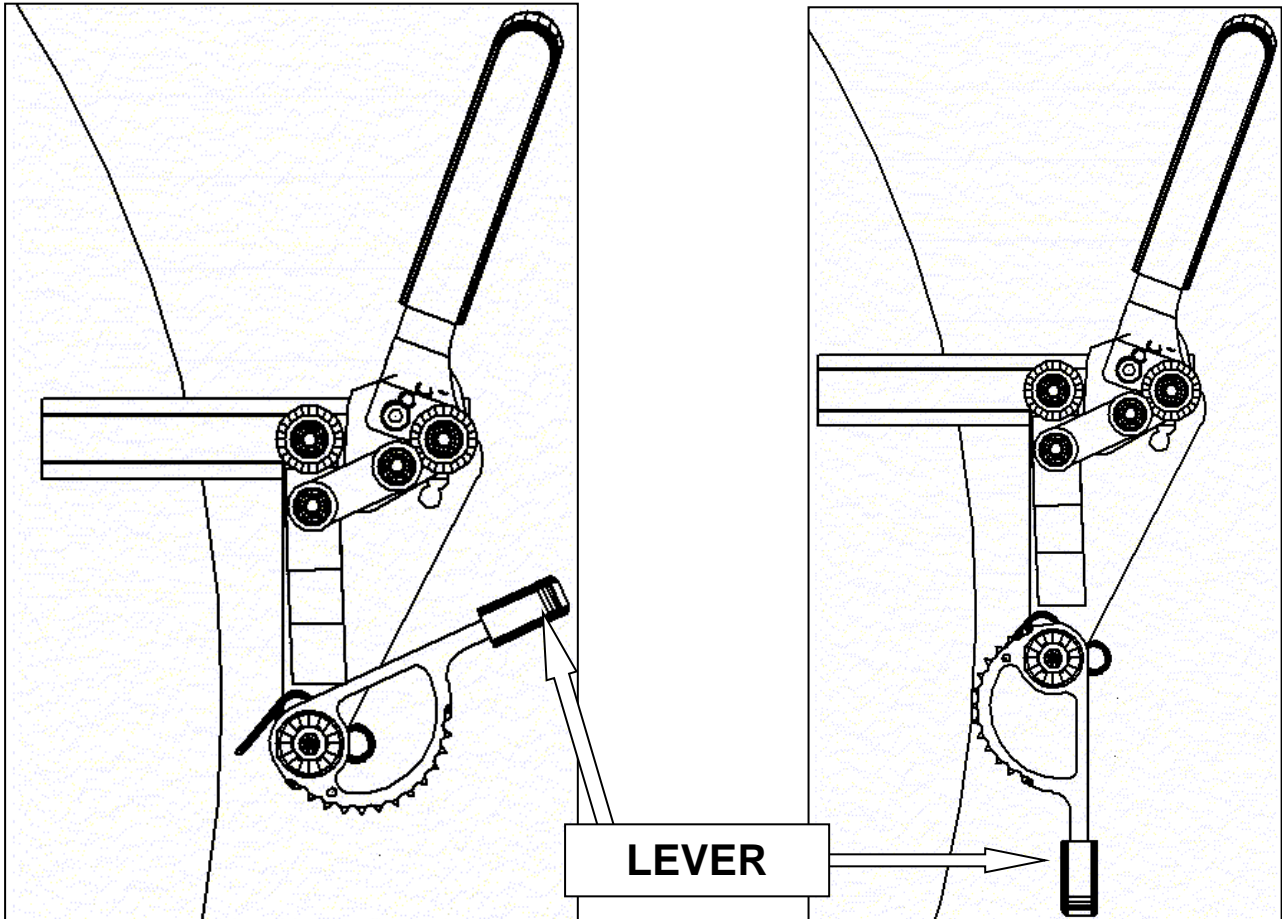

**Figure 36-A: Anti-reverse DISENGAGED. ENGAGED.**

**Figure 36-B: Anti-reverse**

1. To activate the anti-reverse, lower the lever towards the ground, so that the wheelchair cannot roll backwards (see Figure 36-B).
2. To disengage the anti-reverse, pull the lever upwards. The wheelchair can now move backwards (see Figure 36-A).



*Keep your fingers away from this mechanism when propelling.*

## 3.15. ANTI-TIP DEVICE

### 3.15.1. TO REMOVE OR RETRACT

- For easier transport of your wheelchair, you can remove the anti-tip. To do this, simply press the button (A) and pull it downwards out of its housing (see Figure 37-A).
- Alternatively, press button (A) and retract the anti-tip towards the inside of the wheelchair to the opposite housing (see Figure 37-B).

### 3.15.2. RETRACTING

- To negotiate certain obstacles, the anti-tips can be retracted into the wheelchair, or slid upwards until the button (A) locks into place (see Figure 37-C).
- In this situation, a third party should stand behind the back support with both (2) hands on the back support handles.

	<p><i>Never use your wheelchair if the anti-tip devices are not in the propelling position.</i></p>
-----------------------------------------------------------------------------------	-----------------------------------------------------------------------------------------------------

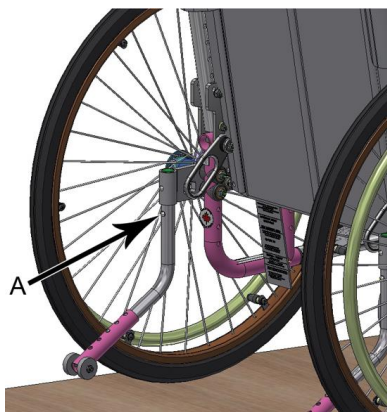

**Figure 37-A: Propelling position**



**Figure 37-B: Retracted position**

## 3.16. PELVIC POSITIONING BELT

For your comfort and safety, make sure that the belt provided with the wheelchair is adjusted to your waist.

	<p><i>Do not modify the belt assembly or attachments.</i></p>
-----------------------------------------------------------------------------------	---------------------------------------------------------------

To adjust the belt length, slide the strap through the plastic loops, making sure that the belt moves in the direction shown in Figure 40-A.

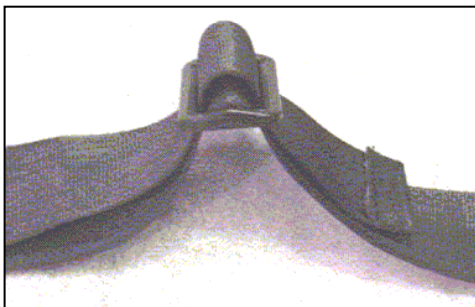

**Figure 40-A: Adjustment of belt length.**

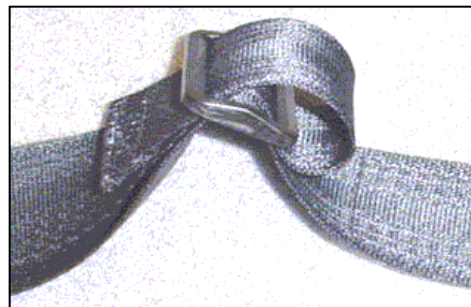
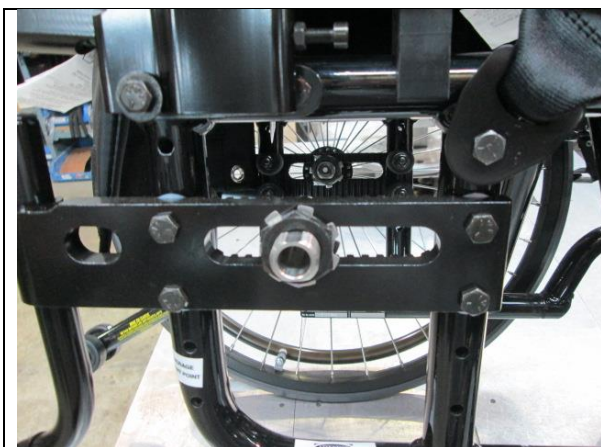

**Figure 40-B Securing belt length adjustment.**

**NOTE:** The free end must always protrude from the plastic loop by three inches (3 in.).

To prevent the belt from slipping, reinsert the free end into the loop, as shown in Figure 40-B.

## 3.17. HIP BELT



The torque required to hold the hip belt in place without breaking the wheelchair is 80 lb-in.

Tightening should be done with a 7/16 in. torque wrench.

Install the hip belt in the location provided (see Figure 34-C).





The belt should be in position A if it is free. If not, use screw B if the multi-position plate is completely in the top.

**Figure 40-C: Torque for hip belt**





## 3.18. SPECIALIZED TRANSIT

The Prima 4 and Prima R comply with BNQ 6645-001 (2019) and ISO 7176-19 (DIS2019) requirements. These models were designed and subjected to frontal impact testing when used as a forward-facing seat in a motor vehicle. The dynamic tests were performed in a forward-facing direction, using a dummy restrained by lap and shoulder belts.

**Do not alter or modify the wheelchair's mounting points or structural and frame parts/components without permission from Orthofab.**

	<p><i>Pelvic positioning belts may be used in a moving vehicle in conjunction with the wheelchair seat belt. However, pelvic positioning belts should not interfere with proper use of the vehicle seat belt.</i></p>
	<p><i>The maximum occupant weight for specialized transit is 300 lbs for Prima 4 and 350 lbs for Prima R. Failure to comply with the maximum weight may increase the risk of serious injury in a collision.</i></p>
	<p><i>Use the motor vehicle seat and its seat belt system when it is physically possible to transfer the occupant and secure the wheelchair with the dedicated restraint system.</i></p>
	<p><i>Do not place any object near the seat belt release button to prevent accidental release.</i></p>



	<p><i>Do not recline the wheelchair seat angle more than 30° when using it as a motor vehicle seat.</i></p>
	<p><i>Do not rely on postural components to restrain the occupant in a moving vehicle.</i></p>
	<p><i>Have the wheelchair inspected for damage if it is involved in a sudden stop. Replace any wheelchair that is involved in a collision.</i></p>
	<p><i>Do not use the tilt function when the seat belt is in use, as it may cause the belt to over-tighten.</i></p>

## 1.1.1 Directions for use

### Section 1 – General information

- The Prima 4 and R models are tested according to the 7176-19 standard, Section 5.2, with specific configuration and components that comply with standard BNQ-6645-001/2019. When used as a seat in a motor vehicle, the wheelchair must be immobilized in a forward-facing position. Other positions have not been impact tested. However, complying with the standard does not preclude use of the rear-facing wheelchair in large, accessible vehicles with rear-facing wheelchair passenger seats.
- The impact tests were conducted with a dummy restrained by pelvic and shoulder belts, and both should be used when the wheelchair is used as the seat in a motor vehicle.
- The shoulder belt, not supplied by **ORTHOFAB**, must comply with Section 5.1 of ISO-7176-19 and be labeled as such.
- A four-point (4) or base anchor system should be used to secure the wheelchair in a motor vehicle (check compatibility of the anchor system with ORTHOFAB).
- Removable components and/or accessories should be secured independently.
- Postural components should NOT be used as a restraint system.

- In their test configuration, the Prima 4 and Prima R wheelchairs weigh 37 lbs and 40 lbs respectively.

## Section 2 – Instructions – Using the wheelchair as a seat in a motor vehicle

### Anchor points

Use the anchor points on the wheelchair, following the directions provided in this note. Look for the following symbol, which indicates anchor points that comply with the ISO 7176-19 standard.



### Pelvic safety belt

- Only use pelvic safety belts that comply with section 5.1 of ISO 7176-19.
- Install the pelvic belt on the anchor points at the back of the wheelchair.
- Thread the pelvic belt between the back support and the arm support.
- Do the same on the other side.

The safety belt angle to the horizontal should be between 30° and 75°. Whenever possible, it is preferable to aim for the higher angle of 75°.

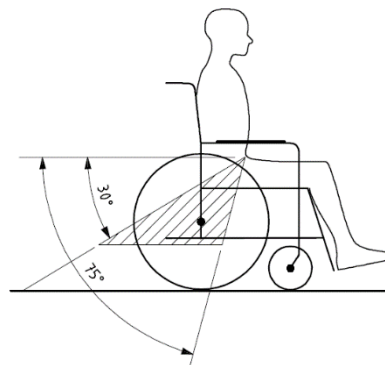

**The belt should pass over the occupant's body and not over parts of the wheelchair, such as arm supports or wheels.**

Les ceintures ne doivent pas être tenues à distance du corps par des composantes du fauteuil tel que les accoudoirs ou les roues



La ceinture de sécurité devrait faire plein contact avec les épaules, l'abdomen et le pelvis. La ceinture pelvienne devrait être basse sur le pelvis près de la jonction entre les cuisses et l'abdomen

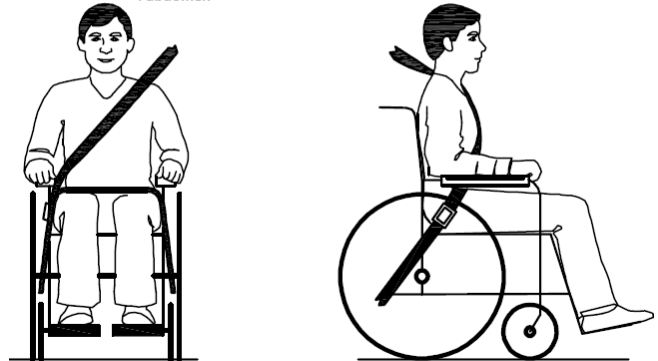

The shoulder belt should fit snugly over the body through the midpoint of the shoulder and across the centre of the abdomen.

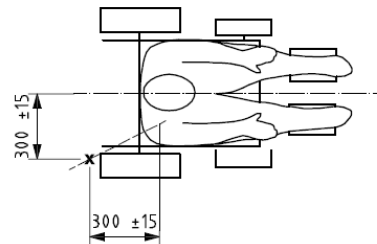
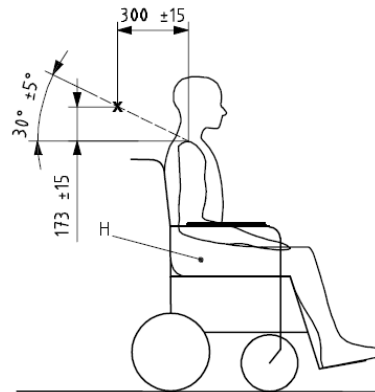
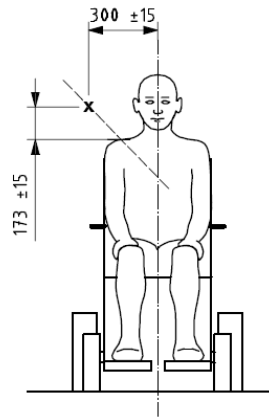

**Make sure the belts are not twisted. They should be adjusted as tightly as possible, allowing for the comfort of the occupant.**



- Install the pelvic belt on the anchor points at the back of the wheelchair.
  - Thread the pelvic belt between the back support and the arm support.
- Do the same on the other side

## 3.18.1. INSTRUCTIONS FOR SPECIALIZED TRANSIT

- Place the wheelchair facing the front of the vehicle in the tie-down area; activate the wheel locks (brakes) and turn off the power if necessary.
- Attach tie-down straps to the vehicle floor anchors as specified by the anchoring system manufacturer.
- Attach the four tie-down hooks at the following locations:

The wheelchair has 4 anchor points (see Figure 41).

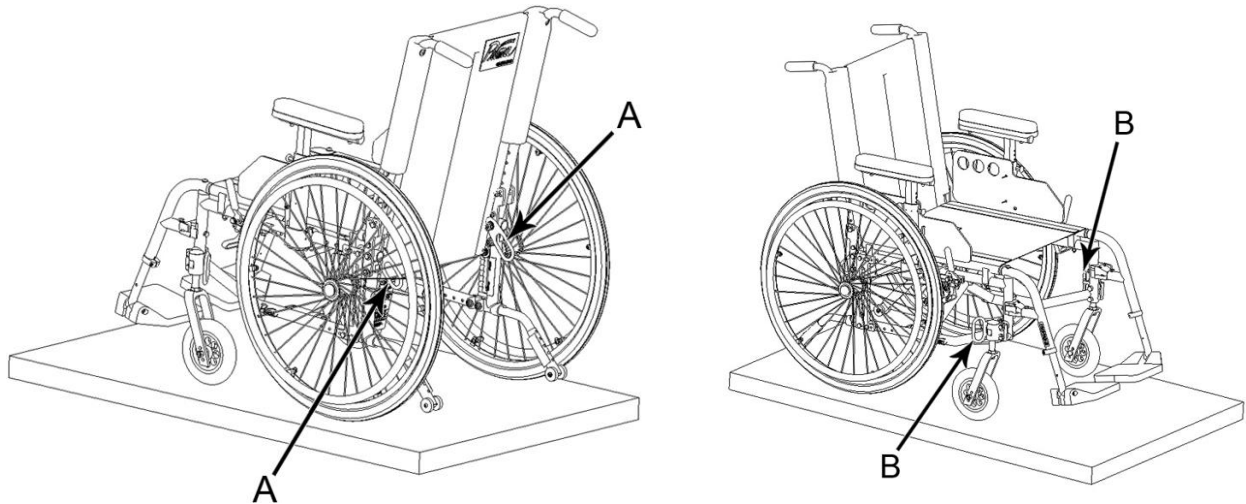

**Figure 41-A: Rear anchor rings.**      **Figure 41-B: Front anchor rings**

There are two (2) anchor rings on the front and two (2) on the back of the wheelchair frame.

	<p><b><i>Never use anything other than these anchor points for transport.</i></b></p>
-------------------------------------------------------------------------------------	---------------------------------------------------------------------------------------

- Check that the tie-down straps are attached at about 45 degrees.
- Do not attach the hooks to the wheels, or to plastic or removable wheelchair parts.
- The brakes must be engaged. Never leave the wheelchair in freewheel mode during transport.
- The carrier should provide you with a seat belt that is attached to the vehicle.

## TIPS FOR TRANSPORTING THE WHEELCHAIR

	<p><b><i>EXTREME CAUTION should be exercised to move the wheelchair up and down stairs. ORTHOFAB strongly recommends that the chair be unoccupied when using a staircase. If the occupant must remain in the wheelchair, three (3) people should perform the maneuver.</i></b></p> <p><b><i>Apply the brakes to secure the wheels;</i></b></p> <p><b><i>NEVER use any detachable components for leverage or use arm or foot supports to lift the wheelchair.</i></b></p> <p><b><i>Lower the leg support assemblies before maneuvering;</i></b></p> <p><b><i>Check that the pelvic positioning belt is securely fastened and adjusted.</i></b></p>
-----------------------------------------------------------------------------------	---------------------------------------------------------------------------------------------------------------------------------------------------------------------------------------------------------------------------------------------------------------------------------------------------------------------------------------------------------------------------------------------------------------------------------------------------------------------------------------------------------------------------------------------------------------------------------------------------------------------------------------------------

## 4. MAINTENANCE

### MAINTENANCE PROCEDURE

<p>Like any other vehicle, your wheelchair needs maintenance to operate safely and efficiently. Routine maintenance will increase your wheelchair's lifespan and efficiency.</p> <p>Take your chair to a qualified dealer or authorized service centre once a year for thorough inspection and maintenance. The screws, nuts and bolts used are non-locking. However, regular cleaning will reveal some parts that may need to be adjusted.</p> <p><b>Checklist</b></p> <p>Initial adjustments should suit your personal needs. For any subsequent maintenance, please follow the procedure below.</p>	Upon delivery	Weekly	Monthly	Periodically
<p>1. General The chair rolls in a straight line and does not pull to one side.</p>	X			X
<p>2. Locking brakes Do not interfere with the wheels when driving. Engage and release easily. Moving parts are not loose or worn.</p>	X		X	
<p>3. Clothing guard Check for bent or protruding parts and make sure all fasteners are secure.</p>	X			X
<p>4. Arm supports Solid but easy to retract.</p>	X			X
<p>5. Arm support upholstery Check for tears - make sure that the base is properly resting on the tube.</p>			X	X
<p>6. Seat and back support covers Check for tears or sagging.</p>			X	
<p>7. 20, 22 and 24 in. rear wheels Is the sealed bearing and nut tension appropriate?</p>	X		X	X
<p>8. Hand rims Check for rough spots or peeling finish.</p>	X			X
<p>9. Front wheels Check for proper bearing by turning the wheel, which should stop gradually. Adjust the bearing if the wheel wobbles or stops abruptly.</p> <p><b>CAUTION:</b> Like any vehicle, the wheels and tires must be periodically checked for signs of wear and replaced if necessary.</p>	X	X		
<p>10. Tires Check for wear. If pneumatic, check air pressure.</p>	X		X	
<p>11. Axles Keep quick release axles clean and oiled (3 in 1 oil).</p>			X	
<p>12. Hand rims Make sure that the hand rims are properly attached to the wheels.</p>			X	
<p>13. Cleaning Clean parts and upholstery.</p>				X

## Tire pressure

The recommended air pressure will usually be marked on one side of the tire. However, if necessary, you can refer to the following table:

6 x 1 ¼ tire	36 psi
7 x 1 ¼ tire	36 psi
8 x 1 ¼ tire	36 psi
8 x 2 ¼ tire	35 psi
20 in. standard tire pressure	65 psi
20 in. high tire pressure	110 psi
22 in. standard tire pressure	65 psi
22 in. high tire pressure	110 psi
24 in. standard tire pressure	75 psi
24 in. high tire pressure	110 psi



***If an adjustment is required, the parts must be tightened BEFORE using the wheelchair and without overtightening to avoid damaging the tubing.***



## 5. TROUBLESHOOTING GUIDE

Wheelchair pulls to the right	Wheelchair pulls to the left	Wheelchair is difficult to propel	Front wheels oscillate	Noise or squeaking	SOLUTIONS
X	X	X			Check tire air pressure
		X	X	X	Check the tightness of the screws and nuts
X	X		X		Check that both front wheels are touching the ground at the <i>same</i> time
X	X				Check the tightness of the spokes
X	X	X	X		Check the angle of the front fork brackets
X	X				Check the rear wheel axle adjustment
X	X	X			Check the front and rear wheel rotation
X	X				Check the front and rear fork rotation

## 6. WARRANTY

**ORTHOFAB** guarantees the wheelchair against any manufacturing defect for a period of five (5) years on the units and components from the date of possession by the insured person.

The warranty applies to units, components, parts, and workmanship in the event of breakage or malfunction due to a defect. The term "defect" refers to any design or manufacturing fault that renders the unit, component, or part unsuitable for the purpose for which it was designed.

Units and components replaced or repaired under any of these warranties are subject to the remaining term of such warranty.

A five (5) year warranty on components added to a unit and on components not replaced under a warranty provided for above from the time of addition or replacement.

If a unit was repaired four (4) times for the same defect or has been out of service for a period of sixty (60) consecutive or non-consecutive days within one (1) year of delivery, the insured person may request a replacement at no charge.

This period begins on the first day on which the unit is out of service. A repair carried out within one day, regardless of its duration, counts as one day. However, **ORTHOFAB** shall not be responsible for delays caused by the lack of availability of the user or the establishment to perform the repair.

A device is considered unserviceable when it cannot perform the functions for which it was designed.

The parts used to repair a unit or component are covered by the remaining warranty of that unit or component.

Replacements and repairs during the warranty period shall be made with original parts and components.

**ORTHOFAB** will repair or replace any defective part if it is returned carefully packaged to prevent further damage and sent (postage prepaid) to an authorized **ORTHOFAB** distributor during the warranty period.

This warranty does not cover mechanical parts or components damaged by abuse, neglect, accident, normal wear and tear or installation not authorized by **ORTHOFAB**.

**ORTHOFAB** guarantees the availability of components and parts necessary for the operation of the wheelchairs for a period of five (5) years from the date of delivery.

This is provided in lieu of any other written, implied, or statutory warranty. **ORTHOFAB'S** liability is limited to the repair or replacement of any part or component, according to the above terms.

## Exclusions and limitations

The above warranty does not apply to products that have been subject to negligence or accident, faulty use, maintenance or storage, or improper use or service. Furthermore, it does not apply to products damaged because of repair or modification without written consent from **ORTHOFAB**, nor to repairs and modifications not performed by an authorized **ORTHOFAB** distributor.

The warranty shall be limited to the repair and, at **ORTHOFAB**'s absolute discretion, the replacement of defective material as provided herein. Except for the warranties set forth herein, **ORTHOFAB** makes no express or implied warranty, statutory or contractual, including for latent defect, nor any implied warranty of merchantability or fitness for a particular purpose relating to its products, except as otherwise provided herein.

The express warranty set forth above is in lieu of any liability or obligation of **ORTHOFAB** for damages arising out of or relating to **ORTHOFAB** products.

In no event shall **ORTHOFAB** be liable for any special, indirect, or consequential damages, whether in contract, tort or otherwise, even if **ORTHOFAB** has been advised of the likelihood of such damages. The distributor's warranty shall be expressly limited to the repair and replacement of non-conforming products as provided herein, or the refund of any amount not exceeding the purchase price of the material involved.

The conditions in section 8 constitute the complete and exclusive warranty statement applicable to **ORTHOFAB** products and shall supersede any prior proposal or agreement, oral or written, and any other communication between **ORTHOFAB** and a particular distributor regarding the **ORTHOFAB** warranty.

**ORTHOFAB** shall not assume any risk for damage incurred during transport.

# ORTHOFAB

---

## NOTES:

Any components exchanged under this warranty shall be covered by the original warranty.

If a component is returned under this warranty, but considered by **ORTHOFAB** as functional, the component will be returned to the customer.

## AUTHORIZED CENTRES

### Technical Aids Services

**CIUSSS du Bas-Saint-Laurent**

800, avenue Sanatorium  
Mont-Joli (Québec) G5H 3L6

**CIUSSS du Saguenay-Lac-Saint-Jean**

2230, rue de l'Hôpital  
Jonquière (Québec) G7X 7X2

**CIUSSS de la Capitale-Nationale**

525, boulevard Wilfrid-Hamel Est  
Québec (Québec) G1M 2S8

**CIUSSS de la Mauricie-et-Centre-du-Québec**

3470, rue Sainte-Marguerite, pavillon G  
Trois-Rivières (Québec) G8Z 1X3

**CIUSSS de l'Estrie**

300, rue King Est, bureau 200  
Sherbrooke (Québec) J1G 1B1

**CIUSSS du Centre-Sud-de-l'Île-de-Montréal**

Centre de réadaptation Lucie-Bruneau  
2305, avenue Laurier Est  
Montréal (Québec) H2H 1C5

**CIUSSS du Centre-Sud-de-l'Île-de-Montréal**

Institut de réadaptation Gingras-Lindsay de  
Montréal  
6300, rue Darlington  
Montréal (Québec) H3S 2J4

**CIUSSS du Centre-Ouest-de-l'Île de Montréal**

CRDP Constance-Lethbridge  
7005, boulevard de Maisonneuve Ouest  
Montréal (Québec) H4B 1T3

**CHU Sainte-Justine**

Centre de réadaptation Marie-Enfant  
5200, rue Bélanger Est  
Montréal (Québec) H1T 1C9

**CIUSSS du Centre-Ouest-de-l'Île de Montréal**

Centre de réadaptation MAB Mackay  
3500, boulevard Décarie  
Montréal (Québec) H4A 3J5

**CISSS de l'Outaouais**

135, boulevard Saint-Raymond

### Addresses

800, avenue Sanatorium  
Mont-Joli (Québec) G5H 3L6

2230, rue de l'Hôpital  
Jonquière (Québec) G7X 7X2

Site François Charron / section adultes  
525, boulevard Wilfrid-Hamel Est  
Québec (Québec) G1M 2S8

3470, rue Sainte-Marguerite, pavillon G  
Trois-Rivières (Québec) G8Z 1X3

300, rue King Est, porte 18-B  
Sherbrooke (Québec) J1G 1B1

2305, avenue Laurier Est  
Montréal (Québec) H2H 1C5

6300, rue Darlington  
Montréal (Québec) H3S 2J4

7005, boulevard de Maisonneuve Ouest  
Montréal (Québec) H4B 1T3

5200, rue Bélanger Est  
Montréal (Québec) H1T 1C9

3500, boulevard Décarie  
Montréal (Québec) H4A 3J5

135, boulevard Saint-Raymond  
Gatineau (Québec) J8Y 6X7

Gatineau (Québec) J8Y 6X7

**CISSS de l'Abitibi-Témiscamingue**

CH SAT Amos  
622, 4e Rue Ouest  
Amos (Québec) J9T 2S2

622, 4e Rue Ouest  
Amos (Québec) J9T 2S2  
7, 9e Rue  
Rouyn-Noranda (Québec) J9X 2A9

**CISSS de l'Abitibi-Témiscamingue**

CRDP Rouyn-Noranda  
7, 9e Rue  
Rouyn-Noranda (Québec) J9X 2A9

915, rue Germain  
Val-d'Or (Québec) J9P 3Y1

**CISSS de la Côte-Nord**

1250, rue Lestrat  
Baie-Comeau (Québec) G5C 1T8

1250, rue Lestrat  
Baie-Comeau (Québec) G5C 1T8

**CISSS de la Gaspésie**

230, route du Parc  
Sainte-Anne-des-Monts (Québec) G4V 2C4

450, avenue Évangéline  
Sept-Îles (Québec) G4R 2N5

230, route du Parc  
Sainte-Anne-des-Monts (Québec) G4V 2C4

**CISSS de Chaudière-Appalaches**

9500, boulevard du Centre-Hospitalier  
Charny (Québec) G6X 0A1

9500, boulevard du Centre-Hospitalier  
Charny (Québec) G6X 0A1  
253, Route 108  
Beauceville (Québec) G5X 2Z3

**CISSS de Laval**

Hôpital juif de réadaptation de Laval  
560, boulevard Cartier Ouest  
Laval (Québec) H7V 1J1

560, boulevard Cartier Ouest  
Laval (Québec) H7V 1J1

**CISSS de Lanaudière**

1075, boulevard Firestone, bureau 1000  
Joliette (Québec) J6E 6X6

1075, boulevard Firestone, bureau 1000  
Joliette (Québec) J6E 6X6

**CISSS des Laurentides**

11, rue Boyer  
Saint-Jérôme (Québec) J7Z 2K5

**CISSS Montérégie-Ouest**

**5300, chemin de Chambly  
Saint-Hubert (Québec) J3Y 3N7**

5300, chemin de Chambly  
Saint-Hubert (Québec) J3Y 3N7

730, rue St-Pierre Est  
St-Hyacinthe (Québec) J2T 1N2

250, Chemin Christ-Roi  
Châteauguay (Québec) J6J 4G7  
Delivery of parts and components only:

388, rue Lamarre  
Longueuil (Québec) J4J 1T2

# ORTHOFAB

---

## ORTHOFAB

### Customer Service Centre

2160, De Celles  
Québec (Québec)  
G2C 1X8

(418) 847-5225  
(800) 463-5293

***Prima 4***  
***Prima R***

01218-0-00\_rev.20211126